



External Cavity Diode Laser Controller

DLC102, DLC202, DLC252, DLC502



Revision 9.55

Limitation of Liability

MOG Laboratories Pty Ltd (MOGLabs) does not assume any liability arising out of the use of the information contained within this manual. This document may contain or reference information and products protected by copyrights or patents and does not convey any license under the patent rights of MOGLabs, nor the rights of others. MOGLabs will not be liable for any defect in hardware or software or loss or inadequacy of data of any kind, or for any direct, indirect, incidental, or consequential damages in connections with or arising out of the performance or use of any of its products. The foregoing limitation of liability shall be equally applicable to any service provided by MOGLabs.

Copyright

Copyright © MOG Laboratories Pty Ltd (MOGLabs) 2007 – 2025. No part of this publication may be reproduced, stored in a retrieval system, or transmitted, in any form or by any means, electronic, mechanical, photocopying or otherwise, without the prior written permission of MOGLabs.

Contact

For further information, please contact:

MOG Laboratories P/L
49 University St
Carlton VIC 3053
AUSTRALIA
+61 3 9939 0677
info@moglabs.com
www.moglabs.com

Santec LIS Corporation
5823 Ohkusa-Nenjozaka, Komaki
Aichi 485-0802
JAPAN
+81 568 79 3535
www.santec.com

Preface

Diode lasers can be wonderful things: they are efficient, compact, low cost, high power, low noise, tunable, and cover a large range of wavelengths. They can also be obstreperous, sensitive, and temperamental, particularly external cavity diode lasers (ECDLs). The mechanics and optics needed to turn a simple \$10 120 mW AlGaAs diode laser into a research-quality narrow-linewidth tunable laser are fairly straightforward [1, 2, 3, 4], but the electronics is demanding – and, until now, not available commercially from a single supplier, let alone in a single unit.

The MOGLabs range of ECDL controllers change that. With each DLC unit, we provide everything you need to run your ECDL, and lock it to an atomic transition. In addition to current and temperature controllers, we provide piezo drivers, sweep ramp generator, modulator for AC locking, lock-in amplifier, feedback servo system, laser-head electronics protection board, even a high-speed low-noise balanced photodetector.

We would like to thank the many people that have contributed their hard work, ideas, and inspiration.

We hope that you enjoy using the DLC as much as we do. Please let us know if you have any suggestions for improvement in the DLC or in this document, so that we can make life in the laser lab easier for all, and check our website from time to time for updated information.

MOGLabs www.moglabs.com

Safety Precautions

Safe and effective use of this product is very important. Please read the following safety information before attempting to operate your laser. Also please note several specific and unusual cautionary notes before using the MOGLabs DLC, in addition to the safety precautions that are standard for any electronic equipment or for laser-related instrumentation.

CAUTION – USE OF CONTROLS OR ADJUSTMENTS OR PERFORMANCE OF PROCEDURES OTHER THAN THOSE SPECIFIED HEREIN MAY RESULT IN HAZARDOUS RADIATION EXPOSURE

Laser output can be dangerous. Please ensure that you implement the appropriate hazard minimisations for your environment, such as laser safety goggles, beam blocks, and door interlocks. MOGLabs takes no responsibility for safe configuration and use of your laser. Please:

- Avoid direct exposure to the beam.
- Avoid looking directly into the beam.
- Note the safety labels and heed their warnings.
- When the laser is switched on, there will be a short delay of two seconds before the emission of laser radiation, mandated by European laser safety regulations (IEC 60825-1).
- The STANDBY/RUN keyswitch must be turned to RUN before the laser can be switched on. The laser will not operate if the keyswitch is in the STANDBY position. The key cannot be

removed from the controller when it is in the clockwise (RUN) position.

- To completely shut off power to the unit, turn the keyswitch anti-clockwise (STANDBY position), switch the mains power switch at rear of unit to OFF, and unplug the unit.
- When the STANDBY/RUN keyswitch is on STANDBY, there cannot be power to the laser diode, but power is still being supplied to the laser head for temperature control.

CAUTION Please ensure that the unit is configured for the correct voltage for your AC mains supply before connecting. The supply must include a good ground connection.

CAUTION To ensure correct cooling airflow, the unit should not be operated with cover removed.

WARNING The internal circuit boards and many of the mounted components are at high voltage, with exposed conductors, in particular the high-voltage piezo driver circuitry. The unit should not be operated with cover removed.

NOTE The MOGLabs DLC is designed for use in scientific research laboratories. It should not be used for consumer or medical applications.

Protection Features

The MOGLabs DLC includes a number of features to protect you and your laser.

- Softstart** A time delay (3 s) followed by linearly ramping the diode current (3 s max).
- Circuit shutdown** Many areas of the circuitry are powered down when not in use. The high voltage supply and piezo drivers, the diode current supplies, the coil driver, and others are without power when the unit is in standby mode, if an interlock is open, or a fault condition is detected.
- Current limit** Sets a maximum possible diode injection current, for all operating modes. Note that current supplied through the RF connector on the laser headboard is not limited.
- Cable continuity** If the laser is disconnected, the system will switch to standby and disable all laser and piezo power supplies. If the laser diode, TEC or temperature sensor fail and become open-circuit, they will be disabled accordingly.
- Short circuit** If the laser diode, TEC or temperature sensor fail and become short-circuit, or if the TEC polarity is reversed, they will be disabled accordingly.
- Temperature** If the detected temperature is below -5°C or above 35°C , the temperature controller is disabled.
- Internal supplies** If any of the internal DC power supplies (+5, ± 10 , $\pm 12\text{V}$) is 1 V or more below its nominal value, the respective components (temperature controller, diode current supply) are disabled.

Protection relay When the power is off, or if the laser is off, the laser diode is shorted via a normally-closed solid-state relay at the laser head board.

Emission indicator The MOGLabs controller will illuminate the emission warning indicator LED immediately when the laser is switched on. There will then be a delay of at least 2 seconds before actual laser emission.

Mains filter Protection against mains transients.

Key-operated The laser cannot be powered unless the key-operated STANDBY switch is in the RUN position, to enable protection against unauthorised or accidental use. The key cannot be removed from the controller when it is in the clockwise (RUN) position.

Interlocks Both the main unit and the laser head board have interlocks, to allow disabling of the laser via a remote switch, or a switch on the laser cover.

Extending laser diode and piezo lifetime

At night, switch to standby:

1. Switch the laser diode current off.
Don't adjust the current, just switch the toggle up (off).
2. Switch from RUN to STANDBY.

The temperature controller will continue to operate, so the laser is ready for quick startup the next day. But the laser diode current and piezo voltage will be zero, extending their operating life.

In the morning, switch back on:

1. Switch from STANDBY to RUN.
2. Switch the laser diode toggle down (on).
You don't need to adjust the current, just wait a few minutes for the diode temperature to equilibrate.

You should switch your MOGLabs DLC into STANDBY mode at nights and weekends and whenever the laser is not being used for more than a few hours. Most lasers need to operate only 40 hours during a 168 hour week; thus switching to standby mode can extend the diode and piezo lifetime by a factor of four.

Contents

Preface	i
Safety Precautions	iii
Protection Features	v
Extending laser diode & piezo lifetime	vii
1 Introduction	1
1.1 Basic operation	1
1.2 Passive frequency control	2
1.3 DC locking to an atomic transition	4
1.4 AC locking to an atomic transition	5
2 Connections and controls	7
2.1 Front panel controls	7
2.2 Front panel display/monitor	10
2.3 Rear panel controls and connections	12
2.4 Internal switches and adjustments	15
2.5 Feedback configurations	19
2.6 Digital control	22
2.7 Internal trimpots	23
3 Operation	25
3.1 Initial configuration	25
3.2 Internal scan control	26
3.3 External scan control	28
3.4 DC Locking	28
3.5 AC Locking	31
3.6 Locking using external signals	34

4	Optimisation	39
4.1	Frequency reference	39
4.2	Noise spectra	41
A	Specifications	43
A.1	Compliance voltage	47
A.2	RF response	48
A.3	Sweep saturation and trigger	48
B	Troubleshooting	51
B.1	STANDBY/RUN indicator	51
B.2	Diode OFF/ON indicator	52
B.3	250 kHz modulation	53
B.4	Locking	55
B.5	External sweep	57
C	Mode-hops and BIAS	59
C.1	Scanning	59
D	Using DBR/DFB diodes	65
D.1	Fine current control	65
D.2	DC current feedback	65
D.3	Slow current feedback	66
D.4	Lock saturation	66
D.5	Special options	66
E	Temperature range	67
E.1	Setpoint and limit protection	67
E.2	Setpoint range (negative temperatures)	68
E.3	Temperature controller: additional parameters	68
F	Modulation coils	69
F.1	Field requirements	69
F.2	Coil impedance	70
F.3	Impedance matching	71
F.4	Tuning	72
F.5	Shielding	73
G	External modulators and injection current modulation	75
G.1	Coupling circuit	75

G.2	Injection current modulation	76
H	Photodetector	79
H.1	Photodiodes	80
I	Laser head board	81
I.1	B1040/B1041 headboard	82
I.2	B1045/1046 headboard	83
I.3	B1047/B1240 headboards	85
I.4	Headboard connection to controller	87
I.5	Dual piezo operation	88
J	Control overview	91
K	Connectors and cables	95
K.1	LASER	95
K.2	Photodetector	96
K.3	Interlock	96
K.4	Digital control	97
L	PCB layout	99
M	115/230 V conversion	101
M.1	Fuse	101
M.2	120/240 V conversion	101
	References	105

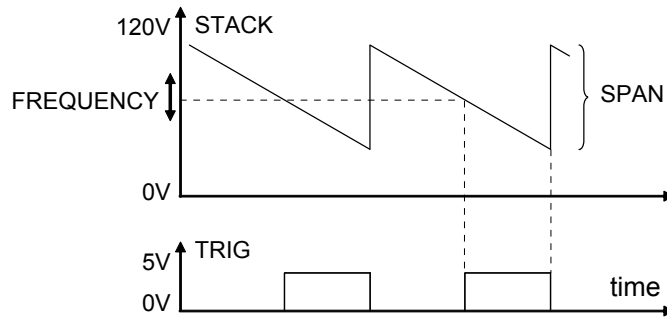

Figure 1.2: Stack (or current bias) output and trigger pulse, when scanning. Note that the ramp slope can be inverted. Details of the ramp behaviour are described in section A.3.

1.2 Passive frequency control

The MOGLabs DLC controls the laser frequency via the diode current, and piezo electric actuators to control the cavity length of an ECDL.

In normal (SCAN) mode, a sawtooth is supplied to the main (STACK) actuator to linearly sweep the laser frequency at a rate determined by the rear-panel trimpot, f_{sweep} , from 4 to 70 sweeps per second; see figure 1.2.

Critical DLC signals can be monitored using the CHANNEL A and CHANNEL B outputs on the rear panel, synchronised to the TRIG trigger output, which should be connected to the equivalent inputs on a two-channel oscilloscope. The particular signals are selected from the front-panel CHAN A and CHAN B selector switches. The signals are described in detail in the following chapter.

Figure 1.3 is an example of what is seen on the oscilloscope in a simple scanning configuration. The laser beam transmitted by an atomic vapour cell is detected on the photodetector provided with the controller, as the laser frequency sweeps through atomic resonances, thus showing the atomic absorption spectrum.

The FREQUENCY knob controls the offset to the piezo-electric actu-

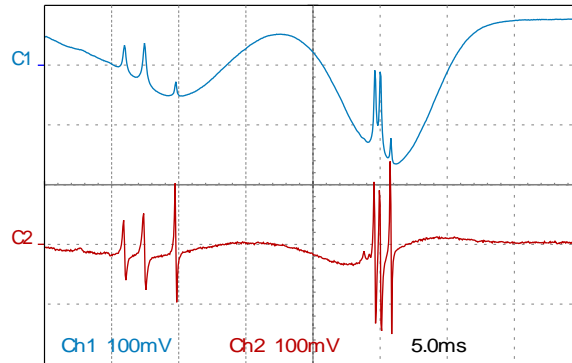

Figure 1.3: A simple absorption spectrum of rubidium with the controller in simple frequency scanning mode.

ator (STACK) and thus the mid-point frequency of the sweep. As the external cavity frequency changes, the laser may “mode-hop” due to competition between the external cavity and the internal cavity defined by the rear and front facets of the diode semiconductor chip itself. The internal frequency of the diode can be adjusted by changing the diode current, either manually as the FREQUENCY offset is adjusted when modehops are observed. The current can also be automatically biased during the frequency sweep, if BIAS is enabled via the internal DIP switch 4; see appendix C. Note that adjusting the frequency offset (FREQUENCY knob) will affect the diode current if BIAS is enabled, but it may still be necessary to adjust the diode current as FREQUENCY is adjusted, to avoid modehops.

The extent of the frequency sweep is controlled with the SPAN control. The maximum range is typically 10 – 100 GHz. Depending on the offset, the span may be limited by the minimum and maximum voltage that can be applied to the actuator, as described in detail in section A.3.

1.3 DC locking to an atomic transition

Figure 1.4 shows one possible configuration in which a MOGLabs DLC is used to lock an ECDL to an atomic transition. Locking is to the side of an absorption peak in a vapour cell; see for example Demtröder [5] for more information on spectroscopy. The passive configuration of §1.2 is extended with the MOGLabs DLC photodetector (see appendix H), and an atomic vapour absorption cell. Alternately, a Fabry-Perot optical cavity or other reference could be used.

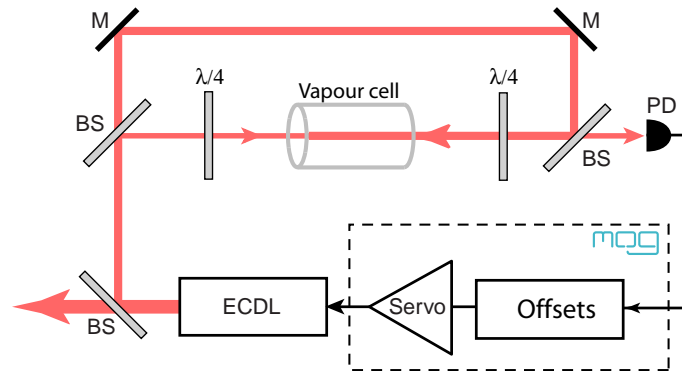

Figure 1.4: Schematic setup for DC locking to an atomic transition. PD is the DLC photodetector. BS beamsplitter, M mirror, $\lambda/4$ a quarter-wave retarder.

The schematic shows a saturated absorption spectroscopy arrangement, but often simply locking to the side of a Doppler-broadened absorption peak will be adequate. The photodetector can be used in single channel mode (default) or with balanced differential inputs, for example to subtract a Doppler background from a saturated absorption spectrum.

The lock frequency is determined by the zero-crossing point of the photosignal. The photosignal offset is adjusted via the INPUT OFFSET and ERROR OFFSET controls. Feedback can be via one or both piezo actuators, or the diode injection current, or all three.

2. Connections and controls

2.1 Front panel controls

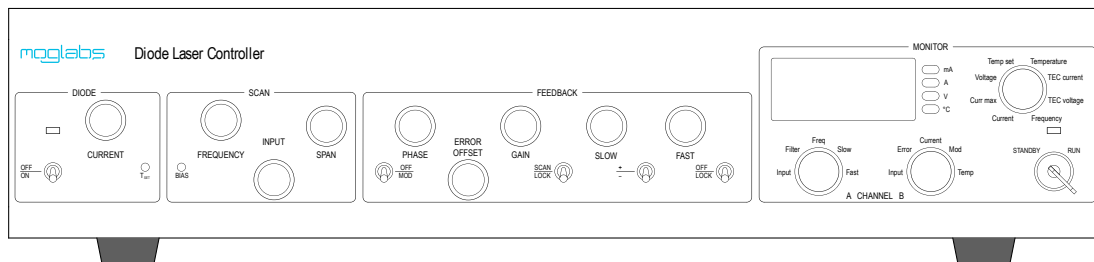

STANDBY/RUN

In STANDBY mode, the DLC maintains the laser temperature, but powers down all other components including the high-voltage piezo power, and the main on-board low-voltage power.

In RUN mode, the DLC activates all circuits, including the laser current driver and piezo drivers. The diode current is disabled, and the STACK is on but not scanning, until the laser enable switch is ON.

On first power-up, the STANDBY indicator will be red; this is normal and indicates there has been a power failure since last switched to RUN. The unit should then be set to RUN to initiate temperature control, and back to STANDBY if further operation is not desired.

If the unit fails to switch to RUN mode (indicator does not show green), see appendix B.

OFF/ON

Diode injection current enable. Also activates the STACK ramp and current bias (if DIP switch 4 in ON). The STANDBY/RUN key switch must first be on RUN and the associated indicator must be green.

If the unit fails to switch to RUN mode (indicator does not show green), see appendix B.

CURRENT	Diode injection current, 0 to 100/200/250/500 mA (DLC102 to DLC502). The response is not linear; that is, the change in current varies for a given rotation of the knob. The mid-range sensitivity is reduced to allow greater precision at normal operating currents.
FREQUENCY	The laser frequency will normally be controlled via a multilayer piezo-electric actuator (STACK). This knob controls the offset voltage applied to that actuator, 0 to 120 V (or 150 V; see LK2, p. 15). For DFB/DBR diodes, the frequency control feedback signal can control the diode current rather than the stack; see §2.4, DIP switch 16.
<i>Note</i>	The FREQUENCY control will also affect the diode current, if BIAS (DIP switch 4) is enabled.
SPAN	Frequency scan range, from 0 to 120 V (or 150 V; see LK2, p. 15). The span may be limited by the minimum and maximum voltage that can be applied to the actuator; see detailed description in section A.3.
PHASE	When AC locking, the controller demodulates the error signal from the detected light intensity. PHASE adjusts the relative phase between the internal reference modulator and the detected signal, from 0 to 360°. When DC locking, the sign of the error signal can be flipped by rotating the PHASE control.
GAIN	Overall error signal gain, 0 to 40 dB.
SLOW	Gain for feedback to the slow (piezo) actuator, 0 to 40 dB.
FAST	Gain for fast feedback to the diode current, 0 to 40 dB.
T_{set}	Temperature set point, 0 – 30° standard. Range can be extended; see appendix E.
BIAS	Feed-forward bias current. If DIP switch 4 is ON, changes in laser frequency, usually via the STACK actuator, will simultaneously change the current. This trimpot controls the slope di/df of current with frequency. It can be positive or negative, with a range of ± 25 mA for the full frequency span. See appendix C for more details.

INPUT OFFSET	Offset of input light intensity signal, 0 to -10 V. This can be adjusted to bring the photodetector light signal close to zero on the oscilloscope, and to shift the zero frequency lockpoint for DC locking.
OFF/MOD	Modulator enable, to switch on the coil driver, diode current dither, or external modulator.
ERROR OFFSET	Offset of the frequency error lock signal. The DLC will lock such that the error signal plus ERROR OFFSET is zero, allowing for small adjustment of the lock frequency.
SCAN/LOCK	Switch between scanning mode and lock mode. When switching from scan to lock, the controller will first reset the scanning actuator (usually STACK) to the offset voltage at the trigger point, and then lock to the nearest frequency at which the error signal is zero.
+/-	Sign of fast (current) feedback. The sign of the slow feedback can be changed with the PHASE control, for both AC and DC locking.
OFF/LOCK	Enable fast (current) feedback. The laser can be locked with slow (piezo) locking or fast (current) locking alone. Best performance is usually obtained with both channels of feedback; see chapter 4 for feedback optimisation.

2.2 Front panel display/monitor

Display selector

The MOGLabs DLC includes a high-precision 4.5 digit LED display with four unit annunciators and 8-channel selector switch.

Current	Diode current (mA) * <i>see note below</i>
Curr max	Current limit (mA) (-) sign indicates limit rather than actual current
Voltage	Diode voltage (V)
Temp set	Temperature set point (°C)
Temperature	Actual temperature (°C)
TEC current	Current to thermoelectric (Peltier) cooler (A)
TEC voltage	Voltage on thermoelectric (Peltier) cooler (V)
Frequency	Frequency actuator offset, usually slow piezo (normalised to a range of ± 1)

Note

The current display shows the current set point, not the actual diode current. If BIAS is enabled, then during the scan the actual diode current will be higher or lower than that shown, depending on the adjusted value of the BIAS trimpot. The current limit circuit prevents the actual diode current from exceeding the limit set by I_{\max} (see page 13), even if the current setting plus current modulation (internal, external, or BIAS) would exceed I_{\max} .

Use CHAN B Current to see the actual diode current, and the effect of BIAS and current limit when scanning.

CHAN A

Several important signals can also be monitored externally with an oscilloscope via the rear connectors CHANNEL A, CHANNEL B and TRIG. The outputs to these can be selected with the CHAN A and CHAN B selectors.

Input	Photodetector [30 mV/ μ W]
Filter	Filtered photodetector, 40 kHz low pass
Freq	Frequency-scanning actuator (STACK) [1 V/48 V]
Slow	Slow feedback STACK [1 V/0.24 V] DISC [1 V/4.8 V]
Fast	Current feedback [1 V/100 μ A]

CHAN B

Input	Photodetector [30 mV/ μ W]
Error	Feedback error
Current	Diode current [10 V/A (4 V/A for DLC502)]
Mod	Modulator output current [1 V/A]
Temp	Temperature error [10 V/ $^{\circ}$ C]

2.3 Rear panel controls and connections

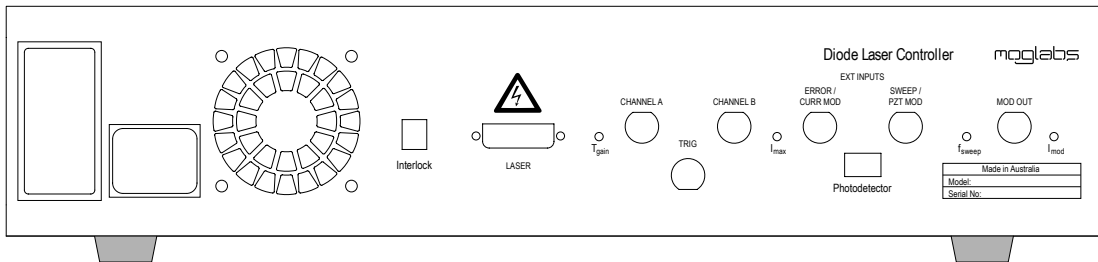

IEC power in/out

The unit should be preset for the appropriate voltage for your country. Please see appendix M for instructions on changing the power supply voltage if needed.

The output IEC connector is a direct connection to the input power, after the input mains filter. This outlet should be used only to power a monitoring oscilloscope. It is provided to minimise ground-loop noise problems.

Fan

The fan speed is temperature-controlled.

Interlock

The DLC will not power on the laser unless the pins on this connector are shorted. A standard 2.1 mm DC plug is provided.

LASER

Connection to laser head. This connector provides diode current, two piezo drives, temperature sense, and TEC current. A DVI-D Dual cable is provided.

WARNING

The piezo drive signals can be lethal. The high-voltage outputs, diode current and TEC current will be disabled if the cable is disconnected, or if the main or head interlocks are open-circuit, but these protection features should not be assumed.

Note

Most computer display DVI cables will *not* work. See appendix K for further information.

T_{gain}	Temperature control feedback gain. Increase this if the response time is too great or if the temperature error is large. Reduce this if the temperature oscillates.
CHANNEL A, B	Monitor outputs; connect to oscilloscope, channels 1 and 2.
TRIG	Oscilloscope trigger, TTL-level. Connect to external trigger input on oscilloscope. Set oscilloscope triggering for external, rising edge.
I_{max}	Diode current limit. The current limit can be set with the display selector set to Curr max . See page 10 for further information.
ERROR/CURR MOD	<p>Input for externally derived feedback error signal (DIP switch 5) or for current modulation (DIP switch 6). Impedance 5 kΩ. Signal normally $< \pm 1$ V; max ± 8 V.</p> <p>If used for external error, set DIP switch 5 ON. For current modulation, set DIP switch 6 ON. See section 2.4 for more detail.</p>
SWEEP/PZT MOD	<p>Input for externally generated frequency control (DIP switch 9 and/or DIP switch 13) or for piezo DISC modulation (DIP switch 14). This signal is <i>added</i> to the internal error signal if DIP switch 15 is on.</p> <p>If DIP switch 9 is on, the internal sweep ramp is replaced with the external sweep input. In that case, the external sweep signal should be 0 to 2.5 V and should cross 1.25 V to generate triggering for the oscilloscope (TRIG) and locking. Impedance 5 kΩ. Sensitivity 48 V per volt (120 V max).</p> <p>If the external sweep is less than 0 to 2.5 V then the current bias dI/df will be reduced in proportion. The front panel FREQUENCY and SPAN knobs behave normally, controlling the offset and amplitude of the external sweep signal.</p> <p>It is possible to add the SWEEP signal to the internally generated STACK signal in all circumstances, for example to test actuator response while locked to a transition. To do this, add a resistor (approximately 5k0, size 0603) at R113.</p> <p>Signal paths can be found in appendix J.</p>

Photodetector	Connection to photodetector unit. A standard 6-pin FireWire (IEEE-1394) cable is provided.
f_{sweep}	Scan rate, 4 – 70 Hz. Note that the rapid return of the STACK sweep drive can excite mechanical oscillations in the laser. Slower sweeps are recommended; usually 10 or 20 Hz works well but if ringing is observed at the start of the sweep, reduce f _{sweep} .
MOD OUT	Output to drive external modulator. Note that MOD OUT is a <u>current</u> driver, 0 to ± 500 mA (max voltage ± 8 V). The ground return is via a $1\ \Omega$ current sense resistor, so $V_{\text{OUT}} = IR = I_{\text{mod}}$ volts relative to ground. MOD OUT can be directly connected to a $50\ \Omega$ load, giving a voltage of ± 5 V if I_{mod} is adjusted to ± 100 mA. See appendices F, G.
I_{mod}	Modulation depth: the range of current modulation on MOD OUT and if DIP switch 3 is on, the diode current.

2.4 Internal switches and adjustments

See appendix J for schematic overviews of the piezo and diode current control signals, and the effect of the different DIP switches. See appendix L for the location of relevant internal components.

CAUTION

The cover of the controller should be left on, even loosely, to ensure proper airflow and cooling.

Interlock

Link LK1 (rear right of main board) can be shorted internally to avoid the requirement for an external interlock, if permitted by local safety regulations.

120 V

Link LK2 (near LK1 and 160 V test point) can be shorted to limit the piezo stack voltage to 120 V, or removed to increase it to 150 V.

DIP switches

	OFF	ON
1	DISC fixed	DISC ON
2	STACK fixed	STACK ON
3	Current dither OFF	Current dither ON
4	Current bias OFF	Current bias ON
5	Internal error	External error
6	External current mod OFF	External current mod ON
7	AC lock	DC lock
8	Single photodiode	Dual photodiode
9	Sweep internal	Sweep external
10	STACK feedback –	STACK feedback +
11	STACK sweep +	STACK sweep –
12	AC current feedback	DC current feedback
13	STACK internal	STACK external
14	DISC internal	DISC external
15	Default	External slow error
16	Current mod by SLOW control signal (for DBR/DFB)	

- DIP 1, 2** Feedback configuration, see section 2.5.
- DIP 3** Internal current dither. With DIP3 ON, a 250 kHz modulation is applied to the injection current, to cause frequency modulation of the laser frequency and generate an error signal for AC locking (see section 3.5). The modulation depth is adjusted via the I_{mod} rear-panel trimpot. The modulation can be switched on and off via the front panel toggle switch OFF/MOD.
- Caution** Current dither (DIP 3 ON) inherently increases the effective linewidth of the laser. The modulation depth should be adjusted to the minimum that still provides sufficient locking signal.
- DIP 4** Current bias. Enables injection current bias, also called “feed-forward”. When ON, the injection current is modulated in proportion to changes in piezo voltage. The amount of bias is set by the BIAS front-panel trimpot. Appropriate adjustment can substantially extend the mode-hop-free scan range of the laser (see Appendix C).
- DIP 5** External error. When ON, replaces the internally-generated error signal with the externally-derived error signal provided to the ERROR back-panel input (see section 3.6).
- DIP 6** External current modulation. When ON, the ERROR/CURR MOD input is added to the fast servo output before the FAST gain is applied. The sensitivity depends on the FAST gain knob, varying from 0.25 mA/V to 25 mA/V. The input only affects the diode current when SCAN/LOCK is on LOCK.
- DIP 7** DC locking. Switches from AC locking (top of peak) to DC (side of peak) locking. Generally AC is preferred because the noise at the modulation frequency of 250 kHz is much lower than at DC; thus AC locking is largely free of slow drifts. However, for many applications a DC reference is perfectly adequate and allows locking with wider bandwidth.
- DIP 8** Differential photodiode. It can be convenient to subtract a background from the input signal, for example to remove a Doppler back-

ground from a saturated absorption reference. Switch 8 switches the photodetector to differential mode.

DIP 9, 13, 14, 15 These switches determine the function of the SWEEP input on the back-panel (see section 3.3 and 3.6).

DIP 9 External sweep. Set DIP switch 9 ON to replace the internal sweep ramp with an external SWEEP signal. The front-panel SPAN knob acts as an attenuator on the external signal to control the sweep amplitude, and the front-panel FREQUENCY knob controls the offset. The external control signal range is 0 to 2.5 V, and must cross 1.25 V when being used as an external ramp.

DIP 10, 11 The sign of the response of the two piezo actuators can be reversed with switches 10, 11. For example, increasing the potential on STACK may increase or decrease the cavity length, while DISC may act in the same or the opposite sense. It is important for locking that both operate in the same sense. Also, it may be useful to reverse the scan for some applications. To reverse the sign of DISC, reverse the error signal first, and then adjust the sign of the STACK and current feedback.

Note The feedback to the STACK actuator reverses with DIP 1 and so DIP 10 should also be flipped when DIP 1 is flipped, or the PHASE adjusted to reverse the error signal. See also section 2.5.

DIP 12 DC current feedback. Current feedback is normally AC coupled (0.1 s time constant) because slow feedback to STACK takes care of slow drifts. For lasers without piezo control, such as DBR and DFB diodes, switch DIP 12 ON to change to DC feedback to current. DIP 12 has no effect unless FAST lock is on.

DIP 13 External STACK control. If DIP 13 is on, the internally generated STACK voltage is replaced with the external SWEEP signal, independent of the state of SCAN/LOCK. Can be used in combination with external servo controllers (section 3.6). Note that no bias current will be generated if DIP 13 is enabled and DIP 9 should be used instead.

- DIP 14** External DISC control. If DIP 14 is on, the internally generated DISC voltage is replaced with the external SWEEP signal, independent of the state of SCAN/LOCK.
- DIP 15** External slow error. If DIP 15 is on, the external SWEEP input replaces the internally-generated slow (piezo) feedback error signal. The fast (current) feedback path is unaltered, except where overridden by DIP 16; see section 2.5.
- DIP 12, 16** Switches 4, 12, 16 allow operation of DFB/DBR lasers without external cavity feedback and thus with only current as an actuator. See section 2.5 and Appendix D for more details.

2.5 Feedback configurations

The DLC is designed to drive up to three feedback actuators with appropriate frequency bandwidths for each. The actuators are STACK, DISC and CURRENT. Suitable lasers include the MOGLabs ECDL which has CURRENT and STACK feedback but no DISC piezo; DFB/DBR lasers which only offer CURRENT feedback; and lasers with all three.

The nominal feedback bandwidths described below are defined by the unit gain bandwidth when all controls (MASTER, SLOW, FAST) are at their centre positions. The actual closed-loop unity gain frequencies will depend on the particular laser, diode, and piezos used and on the reference signal, so the frequencies are only a guide.

For CURRENT feedback, phase lead adjust can increase the bandwidth to 40 kHz.

Summary of configurations

DIP	16	10	2	1	Description
A	OFF	OFF	ON	ON	STACK slow DISC fast
B	ON	ON	ON	ON	STACK slow DISC fast
C	OFF	ON	ON	OFF	STACK fast DISC fixed
D	OFF	OFF	OFF	ON	STACK fixed DISC fast
E	ON	X	OFF	OFF	STACK fixed DISC fast

For the MOGLabs ECDL, use option C (default) or, to increase the range for slow drift, option B.

The configurations above assume that increasing the voltage on STACK increases the laser frequency (by reducing the cavity length). Reverse DIP 10 if the opposite is true.

A: STACK slow, DISC fast

STACK: -20 dB/decade, BW 50 Hz
DISC: -40 dB/decade, BW 1.5 kHz
CURRENT: -20 dB/decade, BW 15 kHz

B: STACK slow, DISC fast, extra CURRENT

STACK: -20 dB/decade, BW 50 Hz
DISC: -40 dB/decade, BW 1.5 kHz
CURRENT: -20 dB/decade BW 15 kHz + flat response

Additional CURRENT feedback with flat response (no integrator) to boost low-frequency feedback. The combined current feedback gain is reduced $25\times$. In this configuration, the error signal must be reversed; that is, the error signal should have a positive slope at the lock point, the \pm current feedback polarity toggle switch should be down ($-$). Note DIP 10 is ON.

C: STACK fast, DISC fixed

STACK: -40 dB/decade, BW 750 Hz
DISC: fixed
CURRENT: -20 dB/decade, BW 15 kHz

High gain (fast) output to STACK reduces range of STACK to ± 1 GHz before internal signal saturates.

D: STACK fixed, DISC fast

STACK: fixed
DISC: -40 dB/decade, BW 1.5 kHz
CURRENT: -20 dB/decade, BW 15 kHz

E: CURRENT only

STACK: fixed

DISC: fixed

CURRENT: flat, BW 15 kHz

DIP 12 should be ON for DC CURRENT feedback.

DIP 4 ON to drive the current with the scanning ramp.

For DBR and DFB lasers and ECDLs when it is desirable to operate without piezo actuators.

2.6 Digital control

HD12 is a 10-pin header which provides access to several control signals for locking and for sample-and-hold of the lock-point. HD12 is located near the DIP switches, slightly towards the front and left-hand side of the unit (see appendix L). The pinout of the header is described in section K.4. The signals are standard TTL-compatible, $> 2.4\text{ V}$ HIGH and $< 0.8\text{ V}$ LOW. The inputs are ORed with the front toggle switches, such that the signal is activated if either the digital input is active (i.e. HIGH) or the toggle switch is on (down).

Laser ON

HIGH to switch the laser diode current on, regardless of the state of the front-panel switch.

LOCK

HIGH to SLOW lock, regardless of the state of the front-panel switch.
LOW to sweep, if the front-panel switch is up.

FAST

HIGH to FAST lock, regardless of the state of the front-panel switch.

HOLD

HIGH to freeze STACK. With HOLD active, the feedback to the slow piezo will be fixed by a sample-and-hold circuit. The diode current can then be modulated via the rear-panel CURR MOD input (with DIP switch 6 ON), to jump the laser frequency quickly, without the error feedback circuit competing with the external modulation. External current modulation is independent of the FAST lock status, but slow lock must be active (front panel SCAN/LOCK toggle switch down, or HD12 pin 3 HIGH).

FAST lock is asynchronous with HOLD active; that is, the FAST lock will activate immediately, rather than the normal delay until the scan ramp reaches the sweep centre.

To relock, restore the CURR MOD input voltage, and return the HOLD input LOW; the locking feedback will then be reactivated. FAST lock can then be reactivated.

This ability can be used for auto-locking under computer control, and also for atom trapping experiments involving sequences with different detunings for polarisation gradient cooling and for compression.

2.7 Internal trim pots

RT6	Current dither amplitude limit
RT12	Phase lead
RT13	Ambient temp for active sensors (AD590, AD592)
RT15	TEC current limit

RT6 For AC locking, either the laser frequency or the external reference must be modulated at the DLC dither frequency, 250 kHz. An external modulator (see appendix G) is normally used, but the laser injection current can be modulated directly. The modulation depth is then controlled by the rear-panel I_{mod} trimpot. The limit to the current modulation is factory set via RT6.

RT12 A phase-lead circuit is included on the current feedback channel, to boost the output at higher frequencies (tens of kHz). RT12 controls the phase lead and can be adjusted for different diodes; see chapter 4, page 42.

RT13 Offset adjustment for active temperature sensors (AD590, AD592), so that temperature reads in °C.

RT15 Current limit for TEC output. To set, change the set temperature suddenly, and adjust RT15 while reading the TEC current.

3. Operation

3.1 Initial configuration

The MOGLabs DLC has a wide variety of operating modes. The following describes setting up the temperature and current controllers for regular operation. When purchased with a MOGLabs laser, the DLC will be shipped already correctly configured to operate that laser.

For operation with DBR/DFB diodes, see Appendix D. For operation with other non-MOGLabs laser, see Appendix I for connector information.

1. Ensure the power is on, and the STANDBY/RUN switch is on STANDBY. On first power-up, the STANDBY indicator will be red; this is normal.
2. Switch from STANDBY to RUN to initiate temperature control. The indicator should change from red (or orange) to green. If the indicator is not green, ensure that the TEC and temperature sensor are correctly wired.
3. If the controller is switched back to STANDBY, all electronics will be powered down *except for the temperature controller*, which will continue to operate normally.
4. Adjust the temperature setpoint: first select **Temp set** on the display selector, then adjust T_{set} as required via the front-panel trimpot. If required, the temperature control can be optimised by adjusting the rear-panel trimpot T_{gain} to improve the equilibration time.
5. Adjust the current control knob to minimum (fully anti-clockwise).
6. Set the diode maximum current: select **Curr max** on the display selector, then adjust the rear panel I_{gain} trimpot. Note that

the **Curr max** display will show a negative sign (–) as a visual reminder that the *limit* is being displayed.

7. Switch the laser on. The indicator on the laser head board should illuminate, and the front-panel indicator above the switch should turn green.

Note that the SCAN/LOCK and fast-channel OFF/LOCK switches must be set to SCAN and OFF respectively. Other protection features will prevent current flowing to the diode, such as detecting main cable disconnect, open circuit on the rear-panel, or activation of laser head interlocks.

3.2 Internal scan control

In normal (SCAN) mode, a sawtooth ramp is supplied to the piezo (Figure 3.1), causing the laser frequency shift. Typically a photodiode signal is measured as the frequency is swept, to identify resonant features or isolate transitions to lock the laser frequency to.

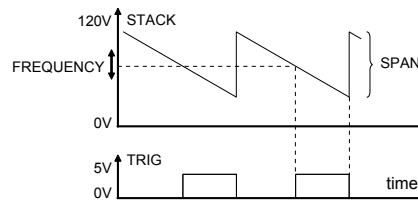

Figure 3.1: Stack output voltage and trigger signal, when scanning.

Several adjustments of the frequency sweep are possible:

FREQUENCY	Frequency offset (mid-point voltage of the ramp).
SPAN	Sets the amplitude of the ramp.
BIAS	Feed-forward bias current adjustment. Can be adjusted to achieve the widest possible mode-hop free scan range. Disabled unless internal DIP switch 4 is ON.
f _{sweep}	Rear-panel trimpot that adjusts the ramp rate (4 to 70 Hz).

Note

The rapid return of the STACK sweep drive can excite mechanical oscillations in the laser. Slower sweeps are recommended; usually 20 Hz works well but if ringing is observed at the start of the sweep, reduce f_{sweep}.

Figure 3.2 is an example of an absorption spectrum acquired with the simple scanning configuration with BIAS current feed-forward. The transmission of the laser through a rubidium vapour cell was detected on the DLC photodetector as the laser frequency was scanned through the $5^2S_{1/2} \rightarrow 5^2P_{3/2}$ transitions.

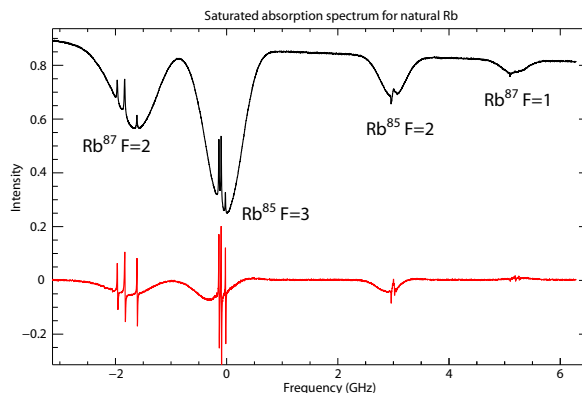

Figure 3.2: A saturated absorption spectrum of rubidium using a standard uncoated laser diode (upper trace). The lower trace shows the AC-modulation error signal (see §3.5).

3.3 External scan control

An external source can be used to control the laser frequency while in SCAN mode. The control signal should be between 0 and 2.5 V and must cross 1.25 V to generate the essential internal trigger required for locking.

1. Connect the external sweep control signal to the rear-panel SWEEP external input.
2. Select external signal by setting DIP switch 9 to ON. Ensure that DIP 12 and DIP 13 are OFF.
3. Toggle DIP switch 11 (the external sweep has reverse polarity to internal sweep).
4. Normally DIP switch 4 should be on so that current bias (feed-forward) is enabled.
5. When SCAN/LOCK is set to SCAN, the external signal will be used. The front panel knobs FREQUENCY and SPAN will then apply offset and attenuation to the external ramp. It is recommended to set FREQUENCY to its midpoint (0V on the front-panel display, with **F**requency selected) and set SPAN to fully clockwise

The internal servo can then be used to lock the laser frequency by switching SCAN/LOCK to LOCK, provided that the external ramp crosses 1.25 V.

Note: if you have a Rev. 8 controller, you will probably need to remove resistor R113; contact MOGLabs for assistance.

3.4 DC Locking

DC locking is typically used to lock to the side of a spectral feature instead of directly on resonance. The error signal in this case is taken directly from the photodiode input signal.

As an example we consider locking the laser to the centre of an

atomic transition. Alternate frequency discriminators, such as a Fabry-Perot cavity, could also be used. A typical schematic for saturated absorption spectroscopy, which is a standard approach to Doppler-free atomic vapour locking, is shown in Figure 3.3.

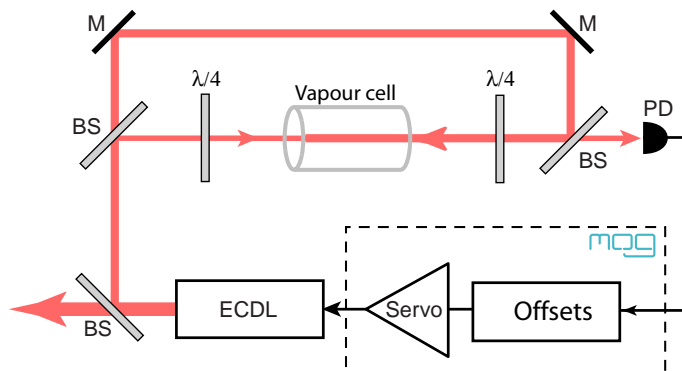

Figure 3.3: Schematic setup for DC locking to an atomic transition. PD is the DLC photodetector. BS beamsplitter, M mirror, $\lambda/4$ retarder.

The photodetector can be used in single channel mode (default) or with balanced differential inputs. Differential mode reduces the sensitivity to changes in laser power, and allows subtraction of the Doppler background from a saturated absorption spectrum.

When DC locking, it is also important to prevent the photodetectors from measuring fluctuations in ambient light (e.g. fluorescent room lights). MOGLabs photodetectors are lensed and filtered to minimise the influence of background light, but best results will be obtained when using a filter or shield.

Sample oscilloscope traces obtained in DC locking (“side of fringe”) mode are shown below, for wide and narrow spans. These traces were obtained with an 8 cm long Rb vapour cell at room temperature.

To operate in DC locking configuration:

1. Select DC locking by setting internal DIP switch 7 to ON.
2. If using differential inputs, set internal DIP switch 8 to ON.

3. Align the beam(s) onto the photodetector input(s).
4. Find an appropriate spectral feature.
5. Adjust the INPUT OFFSET to eliminate the offset in the photodiode signal as seen on the INPUT signal on CHAN A.
6. Adjust the ERROR OFFSET to obtain a zero-crossing in the ERROR signal at the desired lock frequency, which must be on the side of a spectral feature.
7. The slope should normally be negative (depending on DIP switches 10, 11). If necessary, the ERROR signal can be inverted by coarsely adjusting the PHASE control.
8. Set SLOW and FAST gains to minimum (fully anti-clockwise).
9. Switch SCAN/LOCK to LOCK. When the laser is locked, the photodetector (INPUT) signal should be fixed at the value corresponding to the lock frequency.
10. Switch OFF/LOCK to LOCK. It may be necessary to invert the sign of the fast lock with the \pm switch.
11. Increase SLOW and FAST gains to minimise the error signal, ideally using an external audio spectrum analyser. The gains should be increased until the onset of oscillation, and then reduced. See chapter 4 for additional discussion of feedback optimisation.

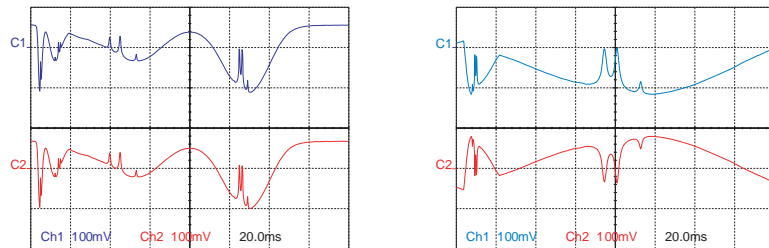

Figure 3.4: Examples of spectra for DC locking, for wide and narrow spans (upper traces) and error signals (lower traces).

Note that it is not necessary to “zoom in” on the desired lock point. The controller will automatically lock to the zero-crossing closest to the trigger point.

3.5 AC Locking

AC locking (“top of fringe” locking) is useful for locking the laser directly to the peak of an atomic resonance, and is less susceptible to drift than DC locking. To derive an error signal, either the laser frequency or atomic resonance needs to be modulated. The DLC can either directly modulate the diode current (see §2.4, DIP switch 3), or drive an external modulator. The external modulator driver has sufficient power to drive a coil directly for Zeeman modulation (Appendix F), or can be used to frequency modulate an acousto-optic modulator.

Two alternative implementations for AC locking using saturated absorption spectroscopy are shown in Figure 3.5 and 3.6. These are similar to the scheme for DC locking, with the addition of a Zeeman coil around the vapour cell which is driven by the DLC.

Figure 3.7 shows sample traces of the photodetector and error signals in AC locking mode, for wide and narrow spans. These traces were obtained with an 8 cm long Rb vapour cell at room temperature using Zeeman modulation at 250 kHz. Note that the Doppler background has been largely removed and there are sharp features around the resonances which result in improved lock performance as compared to DC locking.

To operate in AC locking configuration:

1. Select AC locking by setting internal DIP switch 7 to OFF.
2. Connect the photodetector module and optimise the photosignal on CHANNEL A. The MOGLabs DLC is designed to operate best with about 250 μ W incident on the Si-PIN photodiode.
3. Adjust the INPUT OFFSET such that saturated absorption trace

is near zero.

4. Switch the modulation ON with the OFF/MOD switch.
5. Find an appropriate spectral peak and observe the dispersive error signal with CHAN B set to ERROR.
6. Optimise the error signal (usually for maximum slope) by adjusting the front panel PHASE. The error signal slope should normally be negative (depending on DIP switches 10, 11) at the desired locking frequency.
7. Adjust the GAIN such that the error peaks are roughly 250 – 500 mV peak-to-peak. Note that larger signals do *not* improve lock performance.
8. Adjust front-panel ERROR OFFSET such that the error signal is crossing zero at the desired frequency.
9. Set SLOW and FAST gains to minimum (fully anti-clockwise).

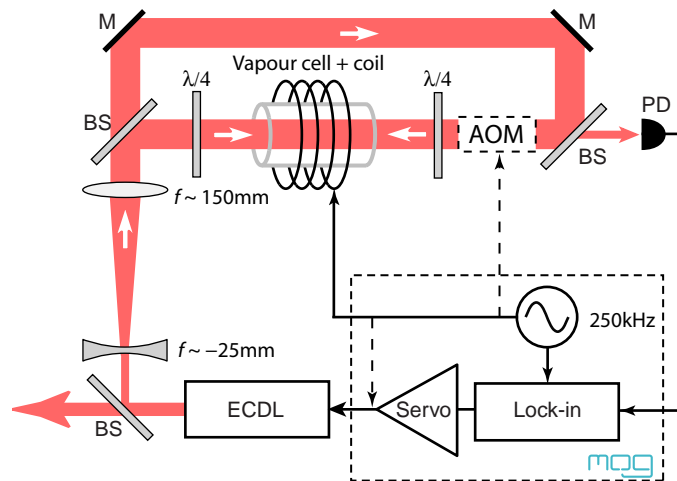

Figure 3.5: Schematic setup for AC locking to an atomic transition with Zeeman modulation. PD is the DLC photodetector. BS beamsplitter, M mirror, $\lambda/4$ retarder. Beam expanding lenses reduce power broadening of the atomic resonance.

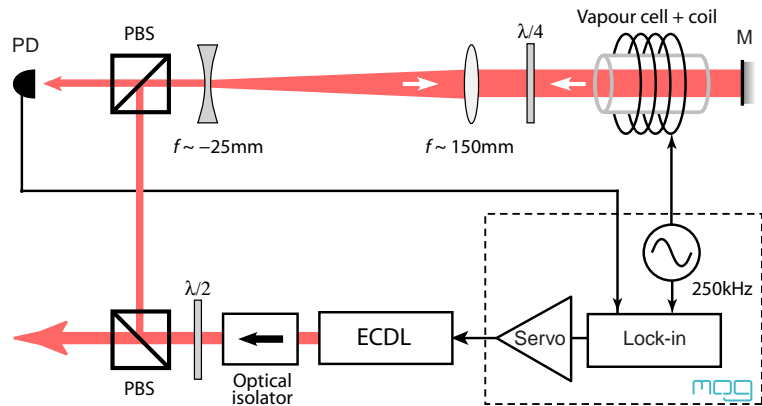

Figure 3.6: Alternative (“retro-reflected”) saturated absorption spectroscopy configuration. PD is the DLC photodetector. PBS polarising beamsplitter, M mirror, $\lambda/4$ and $\lambda/2$ are waveplates.

10. Switch SCAN/LOCK to LOCK. When the laser is locked, the photodetector (INPUT) signal should be fixed at the value corresponding to the lock frequency. If the photodetector voltage jumps after engaging the lock, the servo needs to be relocked.
11. Switch OFF/LOCK to LOCK. It may be necessary to invert the sign of the fast lock with the \pm switch.
12. Increase SLOW and FAST gains to minimise the amplitude of the

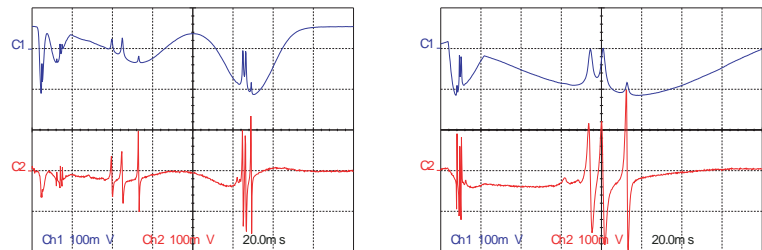

Figure 3.7: Examples of spectra for AC locking, for wide and narrow spans (upper traces), with error signals (lower traces).

error signal fluctuations, ideally using an external audio spectrum analyser. The gains should be increased until the onset of oscillation, and then reduced. See chapter 4 for additional discussion.

Note that it is not necessary to “zoom in” on the desired lock point. The controller will automatically lock to the zero-crossing of the error signal (in this case the peak of a spectral feature) closest to the trigger point, at the centre of the sweep.

3.6 Locking using external signals

The MOGLabs DLC has a wide variety of locking options that make it compatible with many error signal generation techniques as well as external control servos. See appendix G for examples of error signals, and appendix J for block diagrams of the control circuitry for connecting external servos.

It is important to clarify the distinction between *error* and *control* signals: an error signal is a dispersive signal with a potential that depends on laser frequency, whereas a control signal is a feedback servo signal generated from an error signal, usually via a PID (proportional-integral-differential) controller.

When using an external error or control signal, it will normally be advisable to switch off the modulator (DIP switch 3). Note that the bandwidth limit will be the same as for a DLC-generated error signal; that is, about 25 kHz on the fast (current) channel.

3.6.1 Locking to a wavemeter

A common requirement is to lock the laser using a wavemeter with PID control signal output, such as the MOGLabs FZW Fizeau wavemeter or MOGLabs MWM. Usually feedback is to the piezo only because wavemeters are not fast enough for current feedback to be helpful.

The control signal should be between 0 and 2.5V, and at 1.25V when the laser is at the desired frequency. Start with a low gain (sensitivity) on the PID controller, such as 1V/100GHz. The polarity will depend on the laser; for example, positive polarity for a MOGLabs cateye laser and negative for a MOGLabs Littrow laser.

1. Connect the external control signal (i.e. PID output) to the rear-panel SWEEP external input.
2. Select the external control signal by setting DIP switch 9 to ON. Ensure that DIP 12 and DIP 13 are OFF.
3. Normally DIP switch 4 should be ON so that current bias (feed-forward) is enabled.
4. The SCAN/LOCK and fast LOCK should be off (up) to disable the DLC internal locking.
5. Start with the PID controller proportional gain coefficient k_p set to one, and integration k_i and differentiation k_d both zero.
6. Also turn the SPAN knob fully anti-clockwise (minimum). The SPAN knob provides a master gain for the PID feedback.
7. Adjust the laser close to the desired wavelength, and enter the exact desired wavelength as the setpoint in the PID controller.
8. Activate the PID controller, and increase SPAN until the laser frequency is pulled towards the setpoint.
9. Increase the integration coefficient k_i on the PID controller until the laser frequency reaches the setpoint.

3.6.2 External error signal

To operate with externally generated *error* signal, but using the internal DLC servo PIID feedback control:

1. Connect the external error signal to the rear-panel ERROR external input.
2. Select the external locking signal by setting internal DIP switch

5 to ON. If DIP switch 6 is ON, then it should be switched OFF and the BIAS will need to be adjusted.

3. Follow the procedure for AC or DC locking as appropriate.

3.6.3 External piezo lock (with internal ramp)

It is possible to combine the use of the internal DLC ramp with an external control signal, which is useful for combining the front-panel controls with the output of an external PID such as that provided by a wavemeter.

To combine the internal and external control signals requires modification of the DLC PCB and installation of a SMD resistor. Note the supplied signal is then *always* added to the internal signal, and should be zero while scanning the DLC.

1. Locate R113 near the DIP switches (see figure 3.8).
2. Install a 0603 package SMD resistor with nominal value 5k.
3. Connect the required external control signal to the rear-panel SWEEP input.
4. Ensure DIP switch 9 is OFF.

3.6.4 External piezo lock (with external ramp)

Some servo controllers include their own ramp generators, which in some circumstances may be preferable to the DLC internal ramp.

To operate the DLC in this mode, follow the the instructions for external scan control (section 3.3) and ensure that SCAN/LOCK is on SCAN. The lock must then be engaged via the external servo, and the internal fast servo cannot be used.

Alternatively, if a current bias is not required (i.e. DIP 4 is OFF), DIP 13 and/or DIP 14 can be used to enable control of the piezos directly, while still allowing use of the internal fast servo. The

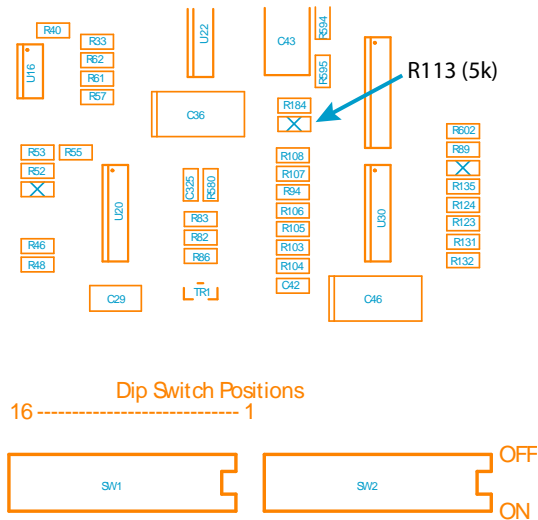

Figure 3.8: R113 is connected so that signals on the rear-panel SWEEP input is always added to the piezo. Remove if using external sweep.

mode-hop free scan range of the laser will typically be reduced as compared to using the internal ramp.

3.6.5 External current lock

An external servo can also be used to control the current of the laser. In most applications that require fast feedback in this way, improved performance can usually be achieved by modulating the laser current directly on the laser headboard (Appendix I) instead of via the DLC.

However, where this option is unavailable or the range of modulation is limited by the headboard, it is possible to modulate the current via the ERROR back-panel input and enabling DIP switch 6.

The external feedback circuit must provide appropriate response. If using current-only control (i.e. no piezo), then PID or PIID is probably appropriate. Otherwise the current control should be AC coupled,

and include gain reduction at high frequencies to avoid servo loop oscillation.

Note that the external current control signal will only be added to the diode current when SCAN/LOCK is set to LOCK.

For the scenario described in subsection 3.6.4 where SCAN/LOCK must be kept on SCAN, DIP12 should be set to ON and SCAN/LOCK should be kept on LOCK instead. This ensures that the externally provided fast and slow control signals are always used by the DLC. The locks must be engaged via the external servos providing the signals.

3.6.6 External current lock and internal piezo lock

In some applications it may be desirable to use a fast external servo to control the laser current, and use the MOGLabs DLC to control the piezo. In this scenario,

1. Connect fast *control* signal to ERROR.
2. Enable fast current control with DIP switch 6.
3. Connect slow *error* signal to SWEEP.
4. Enable slow piezo control with DIP switch 15.

The slow signal should be a dispersive error signal without PID or other servo response function. The fast signal should be AC coupled, and include gain reduction at high frequencies to avoid servo loop oscillation.

4. Optimisation

Laser frequency stabilisation is a complex and ongoing research topic. A thorough treatment would require extensive discussion of control theory, actuator response, mechanical design, laser-atom interactions and electronics. Here we consider the problem from a pragmatic perspective.

The laser is assumed to be moderately stable, operating close to the desired frequency, with a linewidth of a few MHz averaged over a typical measurement time of about one second. The very short-term linewidth is determined by the Schawlow-Townes (S-T) limit, which is typically less than 100 kHz. The MOGLabs DLC will stabilise the laser frequency to an external reference, usually an atomic absorption feature, and reduce the effective linewidth as close as possible to the S-T limit.

Achieving the best frequency locking stability requires careful optimisation of the signal-to-noise ratio (SNR) of the frequency discrimination signal obtained from the saturated absorption or other reference. Then the phase and gain settings must be optimised, preferably by measuring the feedback error signal spectrum.

4.1 Frequency reference

The frequency reference is critical to the performance of the MOGLabs DLC: the controller cannot reduce the laser frequency noise without an appropriate frequency-dependent reference signal.

The DLC has been designed to work with a saturated absorption reference, as shown in figures 3.5 and 3.7. Users should familiarise themselves with saturated absorption spectroscopy, for example as described in Demtröder [5].

The frequency discriminator (“ERROR”) SNR should be optimised to

produce clear (low-noise) dispersive error signals as shown in the upper trace of fig. 3.7. Note that the error signal should be about 0.5 V p-p. While the signal looks cleaner at larger amplitude relative to background oscilloscope noise, in fact the overall performance will deteriorate. Other important factors to consider:

Probe power The probe power should be about 250 μW . Higher power will increase the photosignal, but the detector saturates at about 500 μW .

Probe intensity The probe intensity should be low to reduce power-broadening. Thus, the probe beam should be expanded to 5 or 10 mm diameter, to allow high power and low intensity, as discussed in section 3.5.

Polarisation The frequency discriminator (ERROR) signal is sensitive to the pump and probe polarisations. Good polarisers and careful alignment can be very helpful.

Coil design See appendix F.

Shielding The Zeeman coil produces substantial magnetic fields, oscillating at 250 kHz. These fields can readily induce problematic potentials and currents in the laser head and/or main circuit board. In particular, it is quite possible to produce a larger frequency modulation from induced currents in the laser diode than from the Zeeman modulation of the reference. It is vital that the coil be located far from the main unit and from the laser, or that it be shielded. A layer of high-permeability material (soft iron or mu-metal) is probably adequate. To test this, simply reverse the polarity of the coil connection. If the error signal is also reversed, but otherwise similar, then the shielding is probably adequate.

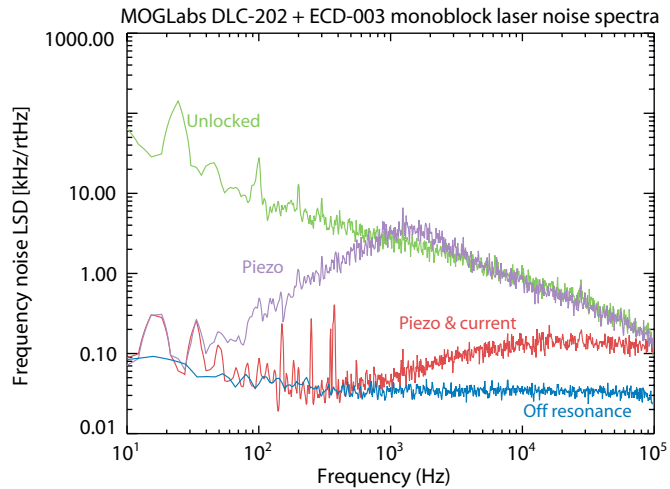

Figure 4.1: Error signal spectra, with laser unlocked, locked with SLOW (piezo) feedback only, and with SLOW and FAST (piezo+current) feedback. The off-resonance spectrum provides information on the effective noise floor.

4.2 Noise spectra

The master, slow and fast gains can be set as described in chapter 3, increasing them until the onset of oscillation, and then reducing slightly. If possible, an audio frequency spectrum analyser can be used to provide better guidance. A generic computer sound card with spectrum analysis software gives reasonable results up to 20 kHz. A good sound card (24-bit 200 kHz, e.g. Lynx L22 or E-Mu 1212m) provides noise analysis up to 100 kHz with 140 dB dynamic range, surpassing most standalone audio spectrum analysers, at very low cost. Connect the spectrum analyser to the CHANNEL B output, and set the CHAN B selector to ERROR.

You should see curves similar to those shown in fig. 4.1. The noise spectrum with laser unlocked was obtained in scan mode, but with zero span, and the frequency carefully set to an atomic resonance (the highest saturated absorption dip in fig. 3.7). Similarly for the *Off resonance* curve, but with the laser tuned far away from all res-

onances, outside a Doppler absorption peak. The *Off resonance* spectrum gives the frequency discriminator noise floor: it is meaningless to try to reduce the laser frequency noise below this level.

With SLOW feedback enabled, the noise for low Fourier frequencies is drastically reduced. A double-integrator is used for slow feedback, such that the suppression is 40 dB/decade. The SLOW gain adjusts the 0 dB gain point; in the figure, this reaches approximately 5 kHz. Higher gains result in oscillation at a frequency corresponding to a pole in the piezo actuator response (i.e. a mechanical resonance).

If configured to work with the stack actuator only (see §2.4), then the SLOW feedback will suppress noise only to a few tens of Hz.

FAST feedback adds an additional 20 dB/decade suppression, with 0 dB gain beyond 20 kHz, even as high as 40 kHz, depending on the diode, optical feedback, the frequency discriminator noise floor and other details. Typically we find that the laser diode itself has a 90° phase lag at 15 to 100 kHz. Some compensation for that phase lag is provided by a phase lead compensator (see RT12, page 23).

Ideally, the SLOW and FAST gains should be adjusted to minimise the integrated noise (the area under the error spectrum). The *Piezo* curve in fig. 4.1 shows a weak “Bode bump” around 1 kHz, indicating very mild excessive slow gain, but no bump in the *Piezo & current* curve. Adjusting RT12 to increase the phase lead until a Bode bump appears could improve the overall frequency noise suppression.

The frequency discriminator SNR – that is, the difference between the *Unlocked* and the *Off resonance* spectra (in the data shown above, about 10 dB for high frequencies) – is critical. Improvements to the reference, for example using a Fabry-Perot etalon rather than saturated absorption spectroscopy, can provide much greater SNR and correspondingly greater laser frequency noise suppression. See §G.2, page 76, for one approach.

A. Specifications

Parameter	Specification
-----------	---------------

Current regulator	
Output current	0 to 100/200/250/500 mA
Max diode voltage	See section A.1
Display resolution	± 0.01 mA
Noise	< 10 nA rms (10 Hz – 1 MHz)
Stability	Warmup time: 15 minutes
CURR MOD	5 k Ω , ± 8 V max, sensitivity 0.25 mA/V to 25 mA/V with DIP 6 on, 1.5 MHz bandwidth
RF modulation	SMA 50 Ω , 160 kHz – 2.5 GHz, see below
BIAS	± 25 mA over full sweep

Temperature controller	
TEC current max	± 2.5 A
TEC voltage max	± 9 V
TEC power max	22 W
Stability	± 5 mK/ $^{\circ}$ C
Sensor	NTC 10 k Ω , AD590, AD592
Range	0–30 $^{\circ}$ standard; extended range optional
Display resolution	± 0.01 $^{\circ}$

Note

The TEC is controlled with a linear regulator, which will overheat if the current load is high and the TEC voltage is low. Choose a TEC with resistance of 4 to 5 ohms to optimise power to the device.

Parameter	Specification
Piezos	
STACK	0 to 120 V for FREQUENCY (default) 0 to 150 V optional (LK2 removed)
DISC	100 ± 16.4 V feedback
Scan rate	4 to 70 Hz

Note

The default maximum piezo voltage is 120 V but can be increased to 150 V by removing jumper LK2; see page 15.

Note

The maximum piezo drive current is 10 mA, which limits the scan rates for piezos with high capacitance. For example, for a 250 nF piezo, the rate should not be greater than 25 Hz.

Photodetector	
Photodiodes	Si-PIN, IR filtered 740 nm – 1100 nm, 1 × 1 mm ² sensor, ±10° field of view See appendix H for spectral response. Options: <ul style="list-style-type: none"> • unfiltered 400 nm – 1100 nm • ± 20°, ±70°
Coupling	AC and DC, single or differential
Diode separation	10 mm
Bandwidth	720 kHz
Dimensions	25 × 25 × 60 mm

Feedback system	
MOD OUT	250 kHz, ± 8 V, ± 500 mA Current output (1 Ω sense) Control via I_{mod} rear-panel trimpot
PHASE	0 to 360° (min)
INPUT OFFSET	-10 V to +10 V
ERROR OFFSET	± 0.5 V
GAIN	MASTER ± 20 dB SLOW MASTER ± 20 dB FAST MASTER ± 20 dB
Bandwidth (gains at midpoint)	SLOW 0 dB at 700 Hz FAST 0 dB at 80 kHz

Protection and status	
External interlock	2.1 mm DC power plug (provided)
Laser head enclosure interlock	2-pin MOLEX connector (provided)
Key switch interlock	STANDBY/RUN
Delayed soft-start	3 s delay + 3 s ramp
Open circuit detect	Laser cable, TEC, temperature sensor
Diode current limit	Rear panel trimpot I_{max}

STANDBY/RUN LED	<p>DARK AC mains off, or fault condition detected (TEC failure, polarity reversed, open-circuit, cable unplugged, missing sensor, temperature out of range)</p> <p>RED AC mains power on</p> <p>ORANGE Standby (temperature controller on)</p> <p>GREEN Fully operational (piezo, current, ramp)</p>
STATUS LED	<p>RED Start sequence error or fault (Either LOCK switch ON, interlock open, head cable disconnected, temperature controller fault detected)</p> <p>ORANGE Ready</p> <p>GREEN Diode running</p>

Mechanical & power	
Display	4.5 digit LED; standard colour red
Fan	12V DC ball-bearing Temperature controlled
IEC input	110 to 130 V 60Hz or 220 to 260 V 50Hz Fuse: 5x20mm, anti-surge (slo-blo) ceramic, 250V/2.5A
IEC output	Common ground with power input Intended for oscilloscope; 1 A max
Dimensions	19" 2U, WxHxD = 422 × 84 × 200 mm
Weight	4.3 kg (excluding cables, laser head board, photodetector). 8 kg shipping
Power	35 W to 70 W (low/high TEC load)

A.1 Compliance voltage

The maximum voltage available to drive current through the laser diode depends on current; see curves below.

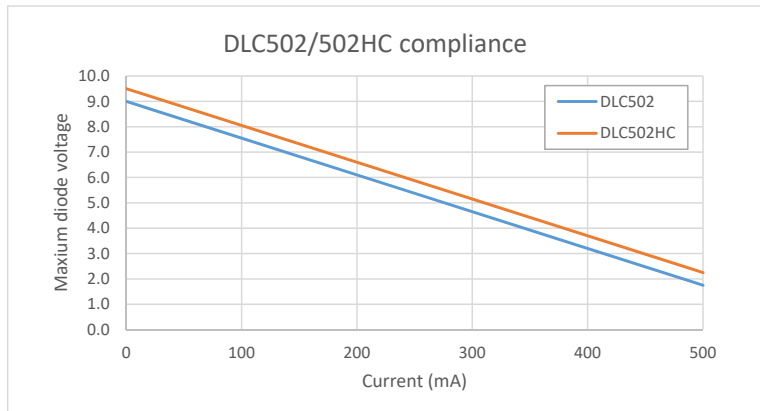
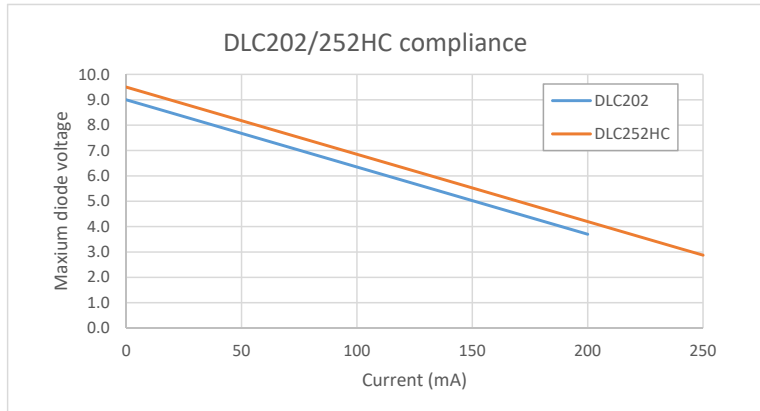

A.2 RF response

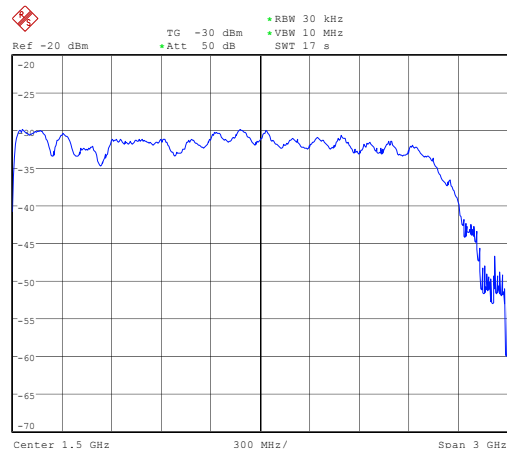

Figure A.1: RF response, SMA input on laser headboard to diode SMA output.

A.3 Sweep saturation and trigger

In normal scanning mode, a sawtooth is supplied to the stack piezo (or other laser frequency actuator), at a frequency of 1 to 70 Hz; see fig. A.2. At the nominal midpoint of the sweep, a trigger (low to high) signal is output via the rear panel TRIG connection, for synchronising to an oscilloscope or external experiment.

The span may be limited by the minimum and maximum voltage that can be applied to the actuator, 0 and 120 V [150 V optional]. That is, the ramp may “saturate”, as shown in fig. A.2. The period remains fixed, and the trigger remains at the centre of the period, but the laser frequency will not scan for the entire period. Thus the spectrum will appear to shift to the left or right of centre and will be “flat” for part of the span. For situations where complete linear spectra are needed, the actual ramp output should be monitored using the *Freq* selection of the CHAN A output.

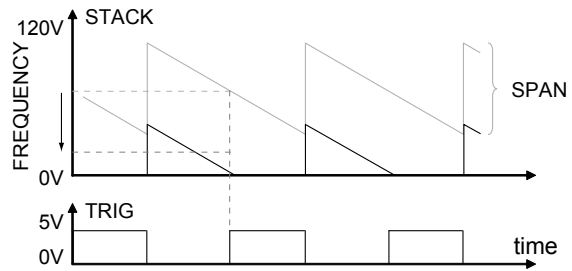

Figure A.2: STACK output voltage and trigger pulse, when FREQUENCY is set near the midpoint (upper) or moved closer to 0V (lower), where the output voltage exceeds the maximum range.

B. Troubleshooting

The MOGLabs DLC detects a wide range of fault conditions and deactivates related circuitry accordingly. The front-panel LEDs provide indication of the state of these functions.

B.1 STANDBY/RUN indicator

Colour	Status
DARK	Temperature controller off. Reset via keyswitch, RUN → STANDBY → RUN Possible faults: <ul style="list-style-type: none">• AC mains off• Interlock(s) disconnected• TEC open or short-circuit• TEC polarity reversed• Cable disconnected• Temperature sensor disconnected• Active temperature sensor connected to thermistor pins• Thermistor connected to active sensor pins• Temperature out of range ($< -5^{\circ}\text{C}$ or $> 35^{\circ}\text{C}$)• External sweep selected (DIP switch 9) but no external sweep supplied• Wrong AC mains voltage
RED	AC mains power failure (temperature controller off)
ORANGE	Standby (temperature controller on)
GREEN	Fully operational (piezo, current, ramp)

B.2 Diode OFF/ON indicator

Colour	Status
RED	Fault Reset via OFF/ON switch ON → OFF → ON Possible faults: <ul style="list-style-type: none"> ● SCAN/LOCK switch not up (SCAN) ● OFF/LOCK switch not up (OFF) ● Rear interlock disconnected ● Laser head interlock disconnected ● Laser head cable disconnected ● TEC disabled (temperature out of range) ● Any one of +5, ±12(aux), ±12V internal supplies below nominal by more than 1 V ● External sweep selected (DIP switch 9) but no external sweep supplied
ORANGE	Standby: above conditions satisfied, diode ready to start
GREEN	Diode fully operational, piezos active

If the indicator remains **ORANGE** after switching the diode ON, check the possible faults listed above, in particular the lack of a clock sync provided from internal or external sweep (see 2.4).

B.3 250 kHz modulation

The 250 kHz sine-wave oscillator relies on critical non-linear behaviour of an electronic component. Due to component drift, the oscillator may cease, and the AC error signal is then lost. A few small adjustments of trimpots will restore the oscillator.

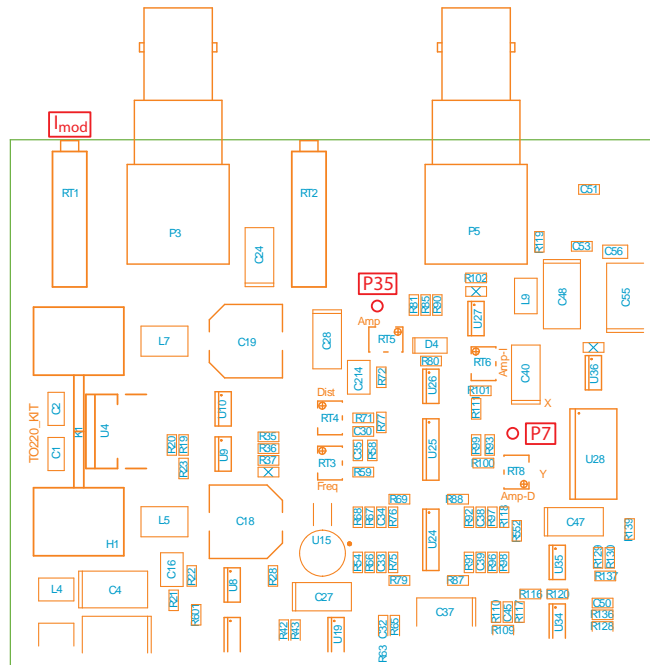

Figure B.1: 250 kHz oscillator trimpots and testpoints.

1. Measure test point P35 (with a multimeter) and adjust RT5 (labelled Amp) for -1.15 volts. P35 is near RT5 Amp trimpot. On older units that don't have P35, you can instead use the anode (left hand side) of diode D4, just to the right of RT5.
2. Probe U25, Pin14 (top pin on right-hand side of U25), and adjust RT4 Dist and RT3 Freq to obtain 2.6V peak-peak, 250 kHz sine wave. RT4 is used to bring the oscillator to life, and adjust the voltage gain. RT3 is used to adjust the

frequency, only. Adjust RT4 first, and once the sine wave appears, adjust RT3 for 250 kHz, then finally adjust RT4 for the 2.6 V p-p. If the oscillator is not stable, try 2.7 V p-p.

3. Probe test point P7 (near RT8 Amp-D and U28), and adjust RT8 to obtain a 1.0 V peak-peak sine wave. On older units that don't have P7, use pin 8 of U25.
4. With the rear-panel I_{mod} trimpot set to maximum (fully clockwise), probe test point P36 (just to the right of U59) and adjust RT6 Amp-I to obtain a 1.0 V peak-peak sine wave. For older controllers (serial numbers with a 7 or smaller number in the 6th digit, e.g. A12027...), P36 does not exist; instead, measure pin 15 of U59.
5. Finally adjust I_{mod} to the required modulation depth, typically about half way (6 turns anti-clockwise).

B.3.1 Disable 250 kHz oscillator

If the 250 kHz oscillator is not required, it can be stopped entirely to remove the very small noise induced in the diode current. To disable the oscillator, first connect an oscilloscope probe to the P7 test point to monitor the 250 kHz signal. Adjust trimpot RT4 Dist clockwise until the oscillation ceases.

B.4 Locking

The MOGLabs controller provides feedback via three channels each with a complex servo loop function. A few common problems are addressed here; for more difficult problems, MOGLabs will be happy to work with you to find the best possible solution.

B.4.1 SLOW does not lock

- Try locking with STACK only, DISC only, or both (see DIP switches 1,2).

It can be very useful to watch the SLOW output (via CHAN A) when locking.

- Try locking with FAST channel only. If FAST locking works but not SLOW, then there is a gain or polarity problem, or a disconnect on one of the slow actuators (STACK, DISC).
- STACK feedback has wrong polarity. See DIP switch 10.
- Lock signal zero-crossing too far from trigger point.
- Gain too high. Try smaller and smaller gain, but be careful to ensure that the lock error signal is crossing zero.
- Loop response too fast for actuator. The controller is normally shipped with slow-channel response gain of 1 (0dB) around 700 Hz. Please contact the factory for instructions on changing this for slower actuators.

B.4.2 SLOW locks only briefly

Usually this is because the STACK feedback has the wrong polarity. Again, it can be very useful to watch the SLOW output (via CHAN A) when locking. Try flipping DIP switch 10. Ensure the laser frequency is scanning properly, i.e. that the STACK is properly connected and working.

B.4.3 FAST does not lock

- FAST feedback has wrong polarity. Try reversing the polarity with the front-panel switch.
- If the laser frequency is close to a mode hop (i.e. intrinsic diode cavity resonance is half way between two external-cavity longitudinal modes), the current response can be opposite to normal. Try adjusting the diode current very slightly.
- Lock signal zero-crossing too far from trigger point.
- Gain too high. Try smaller and smaller gain, but be careful to ensure that the lock error signal is crossing zero.

B.4.4 FAST locks only briefly

The FAST channel is normally AC-coupled (see DIP switch 12), with a time constant of 0.1 s. Thus with FAST feedback only, the laser will drift off resonance. Normally the SLOW channel is used to compensate for very slow drift, but the laser can be locked by current feedback only with DIP switch 10 ON. With DC current feedback, the feedback saturates at ± 10 mA.

B.5 External sweep

Please remember when using external piezo signal (DIP 9 on), your signal must cross 1.25 V. It can be 1.2 to 1.3 V or 0.5 to 1.5 V but not 1.1 to 1.2 V or 1.5 to 2.0 V.

When the signal crosses through 1.25 V, a signal is generated which triggers the control circuits, for example to read the state of the front-panel toggle switches. You can see if that control signal is generated by observing the TRIG output which should transition from low to high periodically. If the TRIG output isn't changing, then the toggle-switch settings are not being updated.

C. Mode-hops and BIAS

Mode-hops are a frequent occurrence with external cavity diode lasers. As the laser wavelength is varied, usually by changing the cavity length with a piezo, competition between the frequency determined by the different frequency-dependent cavity elements can lead to a *mode hop*. Frequency-dependent elements include the external cavity, the laser diode internal cavity between the rear and front facets of the diode, the filter transmission or grating dispersion function, and the gain bandwidth of the laser diode.

The different frequency-dependent characteristics are shown schematically in figure C.1. The net gain is the combined product of semiconductor gain, filter or grating function, internal and external cavity interference. The net gain can be very similar at adjacent external cavity modes. A small change in the internal cavity mode, or the grating or filter angle, can lead to the overall gain being greater at a mode adjacent to the mode in which the laser is oscillating, and the laser then hops to that higher-gain mode. See Ref. [3] for a detailed discussion.

C.1 Scanning

The external cavity length is usually controlled by piezo actuators moving the output coupler. The cavity length changes with piezo voltage, and for a large change, the laser will usually hop to a neighbouring cavity mode. Figure C.2 is a schematic of the net gain variation with frequency, showing two adjacent modes of very similar gain. Figure C.3 is a measurement of the frequency of a laser scanning properly and with a mode-hop at one edge of the scan.

The mode-hop-free scan range (MHFR) can be optimised by careful adjustment of the injection current, which affects the refractive index of the diode and hence the frequency of the cavity mode.

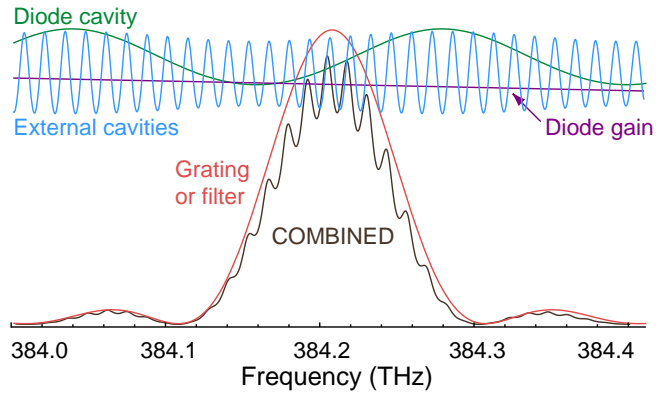

Figure C.1: Schematic representation for the various frequency-dependent factors of an ECDL, adapted from Ref. [3], for wavelength $\lambda = 780$ nm and external cavity length $L_{\text{ext}} = 15$ mm.

C.1.1 BIAS optimisation

This shift of cavity mode frequency allows for compensation of the mismatch of tuning responses. The diode injection current can be “automatically” adjusted as the laser frequency is changed, using a “feed-forward” or current bias which changes as the piezo voltage is changed. Feed-forward current bias adjustment is a feature of MOGLabs DLC controllers. Adjustment is straightforward. With the laser frequency scanning, the current bias control is adjusted until the maximum mode-hop-free scan range is observed. Small changes to the injection current optimise the scan range near the nominal centre frequency. Detailed instructions follow. A Fizeau wavemeter, an atomic absorption spectroscopy signal, or a Fabry-Perot cavity is required, to monitor the actual laser frequency while varying the different control parameters.

1. Make sure that BIAS is enabled (DIP switch 4).
2. Set the FREQUENCY knob to approximately 0V (use monitor display Frequency on the 8-position selector switch).
3. Set the BIAS trimpot to have zero amplitude (use monitor

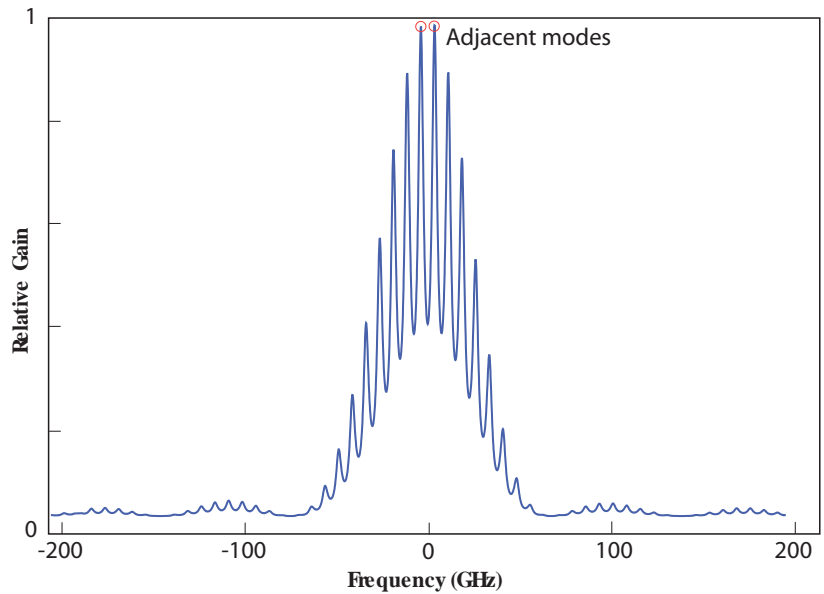

Figure C.2: Combined gain for an external cavity diode laser, including the internal and external modes, the diode laser gain, and the filter or grating response. The broad feature is the frequency selectivity of the filter or grating, and the smaller peaks are the external cavity modes (see fig. C.1). A small relative shift of the external cavity mode relative to the filter or grating frequency will cause the laser to jump to another external cavity mode where the net gain is higher.

CHAN B output set to Current).

4. Adjust the laser diode CURRENT so that the laser wavelength and power are correct. Use the values provided in the original factory test report as a guide.
5. If the wavelength is close but not quite correct, small adjustments of either CURRENT or FREQUENCY may be required to find a better lasing mode. If more significant wavelength adjustment is required, either mechanically rotate the filter (or grating) of the laser, or for changes of less than 0.2 nm, adjust the temperature set-point by 0.2 to 0.5°C. Note that the

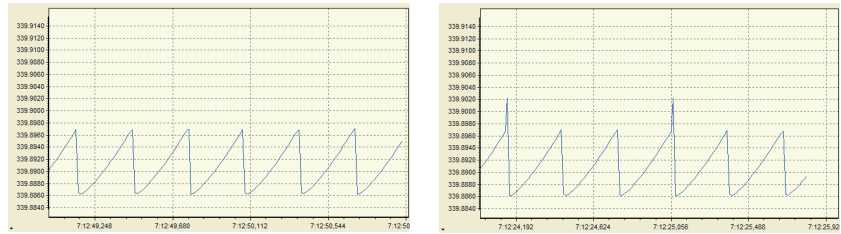

Figure C.3: Frequency of a laser scanning properly (left) and with a mode-hop at one edge (right).

response to adjustment of the temperature setpoint is slow, and you should wait several minutes for the temperature to equilibrate..

6. If the wavelength is within a few pm (GHz) of your target, increase the SPAN while observing the Fizeau wavemeter Long Term measurement (or spectroscopy scan or FP cavity transmission on an oscilloscope), as shown in fig. C.3.
7. As the SPAN is increased, you will at some point observe a mode hop. For spectroscopy scans it is easier to observe mode hops using the AC error signal from the MOGLabs DLC, if current modulation is enabled.

The mode hop should be at one edge of the scan; if so, adjust the FREQUENCY so that the scan no longer 'clips' this mode hop (i.e. the scan is free of mode hops), and continue adjusting in the same direction until a mode hop is observed on the other edge of the scan.

8. Adjust the FREQUENCY to the mid-point between the two extremes.
9. Increase SPAN further, until a mode hop is again apparent, and readjust the FREQUENCY to the mid-point.
10. Repeat until mode hops are observed at both edges of the scan.
11. Adjust the diode CURRENT by small amounts to try to remove

at least one of these mode hops, then attempt to increase the SPAN further.

12. If the mode hops are at both edges of the scan and cannot be removed by FREQUENCY or CURRENT adjustments, turn the BIAS trimpot either clockwise or counterclockwise to remove one of both of the mode hops. If one trimpot direction only makes the mode hops worse, try the other trimpot direction. If both mode hops are removed, repeat the steps above (increasing SPAN) until no further improvements can be made to the MHFR.
13. If the MHFR is substantially less than expected (refer to the factory test report), it may be advisable to change mode by increasing or decreasing the CURRENT to find a nearby single-mode current, or to rotate the filter or grating slightly to alter the net gain so that one cavity mode has higher gain than those adjacent.
14. Iterate FREQUENCY/SPAN/CURRENT/BIAS adjustments until no further improvement in MHFR can be achieved.

D. Using DBR/DFB diodes

DBR (Distributed Bragg Reflector) and DFB (Distributed Feed-Back) diodes offer a compact and robust alternative to ECDLs. The linewidth of DBR and DFB diodes is typically 2 to 3 MHz, and they are very susceptible to external optical feedback, necessitating two or even three stages of Faraday isolator to prevent frequency instability. Their frequency of operation is controlled by temperature and current only, and the DLC must be reconfigured for optimum use without the usual piezo actuator control. The issues are discussed below.

D.1 Fine current control

Without piezo control of frequency, very fine control of the current is required. The coarse CURRENT knob can be used to set the current to within a milliamp or two, and the FREQUENCY knob must then be used. The FREQUENCY knob is normally used to adjust the piezo actuator offset, but it also couples to the current via the current feed-forward (bias). The BIAS trimpot can be adjusted such that the FREQUENCY knob varies the current by up to ± 25 mA. For finer control, the BIAS can be reduced arbitrarily, from fully anti-clockwise (-25 mA range) to fully clockwise ($+25$ mA range). Note that DIP switch 4 must be ON.

D.2 DC current feedback

For locking, the current feedback is normally AC coupled because slow drifts are compensated by the STACK actuator. Change to DC current feedback by turning DIP switch 12 ON.

D.3 Slow current feedback

The feedback signal that normally drives the DISC actuator can be coupled to the current feedback, by turning DIP switch 16 ON.

D.4 Lock saturation

Slow drift is normally compensated by the STACK actuator, and hence the DISC and current feedback signals only have small range, and with DBR/DFB diodes this is easily saturated. Use feedback configuration B (see section 2.5) to maximise the lock range. Dip switch 1 should be ON.

D.5 Special options

Modifications can be made to the controller, including:

1. External control of temperature set-point, for example to enable slow frequency scans via the diode temperature.
2. Very slow locking feedback to the diode current.
3. Very slow locking feedback to the temperature set-point.

Contact MOGLabs for details.

E. Temperature range

The default setpoint temperature range of the MOGLabs DLC products is 0 – 30°C. To change the setpoint range, both the range of the controller and the out-of-limits protection circuit must be changed. Two resistor changes are needed; both are on the top side of the circuitboard. The resistors are 0603 surface mount, 1%, 100 mW. The relevant resistors are near U81 except R335 which is near U87 and R44 which is close to the current-set pot. The resistors can be located in the PCB layout, appendix L, using your pdf viewer (e.g. Acrobat) search function.

E.1 Setpoint and limit protection

R44

Normally 10k; change to 2k to increase temperature setpoint maximum to 50°C. The max setpoint temperature is given by

$$T_{\text{setmax}} = \frac{600k}{10k + R44}.$$

R303

Normally 1k4; change to 2k0 to increase temperature out-of-range limit error to 52°C or 1k82 for 47.5°C. The upper limit of the temperature range $T_{\text{max}}(^{\circ}\text{C})$ is defined by

$$T_{\text{max}}(^{\circ}\text{C}) = 1200 \frac{R303}{R303 + 44k2}$$

and the lower temperature limit is

$$T_{\text{min}} = -1200 \frac{R330}{R330 + 221k}.$$

Thus

$$R303 = \frac{T_{\text{max}} 44k2}{1200 - T_{\text{max}}}.$$

E.2 Setpoint range (negative temperatures)

Resistor changes below will change the temperature range to -30 to $+20^{\circ}\text{C}$. For other ranges, please contact MOGLabs.

R335 from 221k to 43k0.

R331 from DNI to 2k0.

R315 from 1k00 to 1k20.

R305 from 4k99 to DNI.

R44 from 10k0 to 30k0.

E.3 Temperature controller: additional parameters

RT13 Calibration for active sensors (AD590, 592). Set the sensor to a known temperature and adjust RT13 until temperature reads correctly.

RT15 Sets the maximum TEC current. Standard units can drive up to approximately 1.8A if RT15 is set to the maximum (fully CW).

R323 PID proportional gain resistor, nominally 499k in series with Temperature Gain trimpot on rear panel (1M); reduce R323 to 10k for lasers with large thermal capacity, e.g. Toptica DL-100.

R332 PID differential gain resistor, nominally 100k.

R336 PID integrator feedback resistor, nominally 499k. Charges a $100\mu\text{F}$ feedback capacitor; increase to 1M or 2M for lasers with large thermal capacity, e.g. Toptica DL-100.

F. Modulation coils

The MOGLabs DLC is designed to lock to an atomic transition, particularly using AC locking. The frequency of the laser light can be modulated (e.g. using internal current modulation or an external modulator), or the reference can be modulated. In the latter case, an atomic reference can be modulated at low cost using a solenoid coil wrapped around an atomic vapour cell, as shown below.

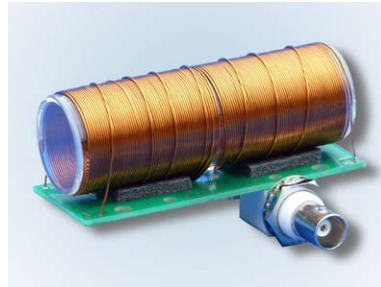

Figure F.1: Vapour cell, Zeeman coil, and primary excitation coil, mounted on PCB (available from MOGLabs).

F.1 Field requirements

Ideally the Zeeman dither coil should produce a frequency shift of about half the peak width, typically a few MHz. Atomic “stretched” state transitions will be Zeeman shifted by

$$\mu_B = \frac{e\hbar}{2m_e} = 1.4 \text{ MHz/Gauss} \quad (\text{F.1.1})$$

so we need fields of around one Gauss (10^{-4} Tesla). The magnetic field inside a long solenoid is

$$B = \mu_0 n i \quad (\text{F.1.2})$$

where n is the number of turns per unit length and i the current. For wire diameter 0.4 mm, $n = 2500 \text{ m}^{-1}$, and the current requirement is only 22 mA/MHz.

F.2 Coil impedance

However, driving an oscillating current through a coil is problematic because the impedance grows with the frequency. The impedance is given by $X_L = \omega L$ where ω is the radial frequency and L the inductance. The inductance for a long solenoid is

$$L = \mu_0 n^2 A l \quad (\text{F.2.3})$$

where A is the cross-section area of the coil (πr^2 for a circular cross-section) and l is the coil length. In practice, the inductance will be less (e.g. see Wheeler [6]):

$$L_{\text{Wheeler}} = \frac{N^2 r^2}{228r + 254l} \quad (\text{mH}) \quad (\text{F.2.4})$$

where N is the total number of turns, r is the coil radius in metres, and l is the length in metres ($l > 0.8r$). We have found that for dimensions typical of coils wound around vapour cells, these two formulae agree within a factor of two.

Note that the inductance increases with n^2 whereas the magnetic field and hence modulation depth grows with n ; thus for our purposes, we generally prefer small n and large currents. On the other hand, the driving voltage requirement (the “back emf”) is given by

$$\epsilon = -L \frac{di}{dt} \quad \epsilon_{\text{max}} = L i_0 \omega \quad (\text{F.2.5})$$

for a sinusoidal current of amplitude i_0 . The required output slew rate is

$$dV/dt = -L \frac{d^2 i}{dt^2} \quad \text{Max} \equiv L i_0 \omega^2. \quad (\text{F.2.6})$$

The MOGLabs DLC operates at $\omega = 250$ kHz. For a cell of length 8 cm, 0.4 mm wire, and 20 mA, we find $L_{\text{Wheeler}} \approx 650 \mu\text{H}$, and $\epsilon_{\text{max}} = 20$ V, and the maximum slew rate is 32 V/ μs .

The MOGLabs DLC does not have that direct output capability. Reducing n helps: inductance, and thus ϵ and dV/dt fall with n^2 while the frequency modulation depth falls with n . Thus a coil of about 40 turns (500 m^{-1}) and current amplitude of 150 mA should result in a modulation depth of 1.3 MHz. However, we prefer to use a two-coil impedance matching arrangement to increase the modulation depth at smaller currents.

F.3 Impedance matching

The DLC can drive up to ± 0.5 A and ± 8 V, with a slew rate of 6 V/ μs . This can be impedance-matched to a high current coil using a transformer, or quite effectively by directly winding a primary on the main Zeeman coil, as shown in the photo above.

For the main Zeeman coil, 0.4 mm to 0.6 mm diameter wire wound around the vapour cell, about 120 to 200 turns, works well. The coil is “balanced” for the standard modulation frequency of $\omega = 250$ kHz using a capacitor. The coil is excited inductively by a primary, about five to ten turns, connected directly to the DLC modulator output (see figure). The cell, coils, and balancing capacitor can be conveniently mounted on a PCB, as shown in the image above, available from MOGLabs.

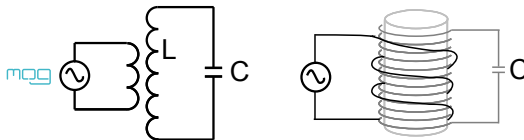

Figure F.2: Circuit diagram for Zeeman coil and excitation coil. Typically the primary is 5 to 10 turns, and the secondary 120 to 200 turns.

The capacitor should be chosen such that the capacitive impedance

equals the inductive impedance. That is,

$$\omega L = \frac{1}{\omega C} \quad C = \frac{1}{\omega^2 L}. \quad (\text{F.3.7})$$

Using the long-solenoid equation for inductance,

$$C = \frac{1}{\omega^2 \mu_0 n^2 A l} \quad (\text{F.3.8})$$

although in practice we find that the inductance is about half the long-solenoid prediction and hence the capacitance should be doubled, typically about 1 to 5 nF. With this arrangement, energy is stored in the inductor-capacitor “tank”, and the DLC need only drive a small current (e.g. 50 mA peak-to-peak) to compensate for losses.

WARNING! The potential across the secondary Zeeman coil can easily be hundreds of volts! Please ensure that your coil and capacitor do not have exposed connections! Also be sure to use capacitors with adequate voltage rating.

F.4 Tuning

To maximise the current in the secondary, the capacitor should be chosen to tune the circuit to the DLC modulation frequency. A spectrum analyser with tracking generator is particularly helpful: connect the coil to the TG output, and to the SA input, and sweep through the resonance (see figure). Alternately, drive the coil with a function generator and measure the magnetic field with another independent coil (e.g. 20 turns of fine wire on a 1 cm diameter former) connected to an oscilloscope. Adjust the capacitor by adding or removing small capacitors in parallel, until the detected field is maximum at 250 kHz. Again, be sure to use capacitors with sufficient voltage rating.

In some cases the Q of the circuit may be *too* high, such that a series resistor of about 0.5 ohm can result in increased current at 250 kHz, and reduced sensitivity to frequency drifts.

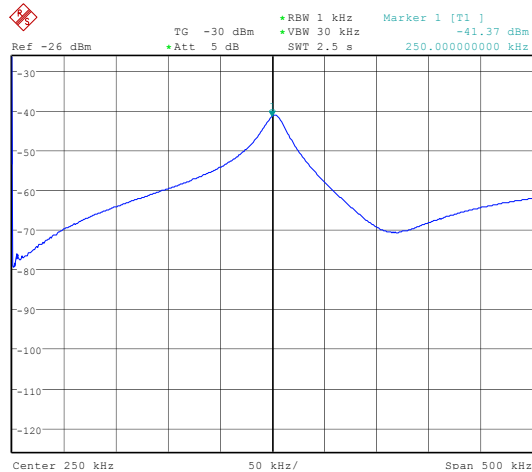

Figure F.3: Coil response acquired using a spectrum analyser with tracking generator. The response shows a strong resonance near 250 kHz.

F.5 Shielding

Large magnetic fields oscillating at 250 kHz can readily cause problematic electromagnetic interference (EMI). Induction in the laser head or the cable to the laser head can easily produce substantial diode current modulation. The coil (and vapour cell) should be located far from the laser and from the controller, or shielded with soft iron or a high permeability alloy such as mu-metal or Conetic. We find that a tube made from thin (0.25 mm) sheet mu-metal, about 50% longer than the cell and coil, is adequate.

G. External modulators and injection current modulation

The MOGLabs DLC is designed for AC locking a laser to an external reference such as an atomic resonance or an optical cavity. In many cases it is convenient to use the internal modulator driver, and Zeeman modulation of an atomic transition, as described in appendix F. Zeeman modulation is not always possible (e.g. if the reference is an optical cavity), or desirable (e.g. due to magnetic interference). The MOGLabs DLC can dither the laser diode injection current (DIP switch 3), or drive an external modulator, such as an electro-optic modulator (EOM) or acousto-optic modulator (AOM).

G.1 Coupling circuit

The DLC provides a current-controlled modulation output, with $1\ \Omega$ sense resistor. It can be directly connected to a $50\ \Omega$ load, producing a voltage of $\pm 5\ \text{V}$ with I_{mod} adjusted to $\pm 100\ \text{mA}$.

Impedance-matching and a DC level shift may be needed to drive an external modulator, as in the schematic below, designed for the D323B RF amplifier from ISOMET.

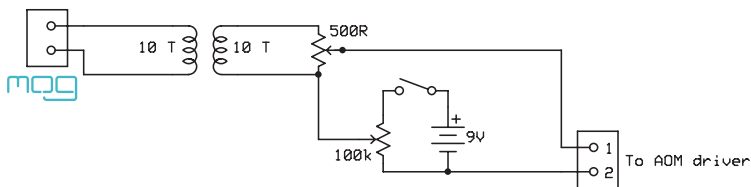

Figure G.1: Coupling from MOD OUT to an external modulator.

The ISOMET D323B RF driver has a frequency control input with 4 to 17V range. We AC couple using a simple 10T:10T ferrite bead trans-

former. Primary and secondary were wound with 10 turns of PVC-insulated hookup wire around a ferrite bead approximately 15 mm diameter. A $500\ \Omega$ potentiometer allows control of the modulation amplitude, and a 9V battery and $100\ \text{k}\Omega$ potentiometer provide a DC shift to set the centre modulator frequency. The latter allows frequency offset control of the modulated light beam.

G.2 Injection current modulation

The MOGLabs DLC can dither the laser diode injection current (set by DIP switch 3), at the standard 250 kHz, or with high frequency modulation (e.g. 10 MHz) via the SMA RF input on the laser headboard. Very narrow linewidths can be achieved with suitably high bandwidth frequency discrimination, for example by phase locking two lasers. The diagram below shows an arrangement to lock two lasers to an EIT (electromagnetically induced transparency) resonance, which obtained a beatnote linewidth below 1 kHz [7].

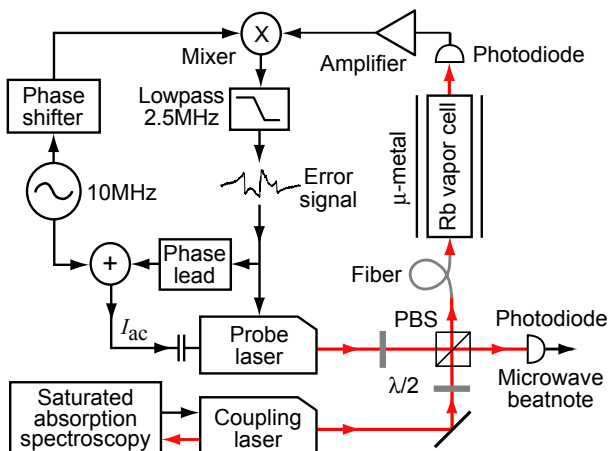

Figure G.2: High bandwidth locking based on FM sideband demodulation [8, 9]. The probe laser is locked with high bandwidth, relative to the coupling laser, using electromagnetically induced transparency as a dispersive reference.

The coupling laser was locked to the $5^2S_{1/2}F = 2 \rightarrow 5^2P_{3/2}F = 2$ transition of ^{87}Rb using the Zeeman modulation technique, as in section 3.5. The probe laser was tuned to the $F = 1 \rightarrow F = 2$ transition and modulated at 10 MHz. The two lasers copropagated through a Rb vapour cell and onto a photodiode. An electromagnetically induced transparency provided a dispersive reference. A frequency error signal was obtained by FM demodulation [8, 9]. The error signal is returned to the external error input on the probe laser MOGLabs DLC, which locked the laser with bandwidth up to about 40 kHz. The error signal was also coupled through a single stage passive phase-lead (high-pass) filter, and then combined with the 10 MHz modulation using a passive bias tee, and injected into the SMA modulation input, to provide feedback bandwidth of about 600 kHz.

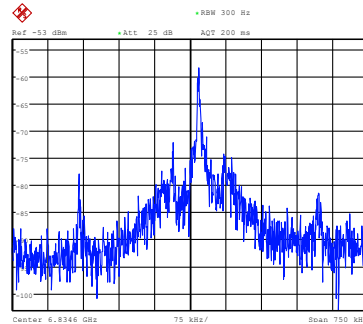

Figure G.3: RF beatnote from two MOGLabs DLC-locked lasers. The -3 dB peak width was 750 Hz with a spectrum analyser RBW setting of 300 Hz. For a 20 s average, the width was about 4 kHz.

H. Photodetector

The MOGLabs photodetector, shown below, can be used as a single detector, or as a differential pair (internal DIP switch 8). The photodetector is connected via the rear socket and cable provided. A number of M4 and 8-32 threaded holes allow mounting in different configurations to minimise the footprint on an optical bench (see figure H.2).



Figure H.1: MOGLabs DLC balanced differential photodetector.

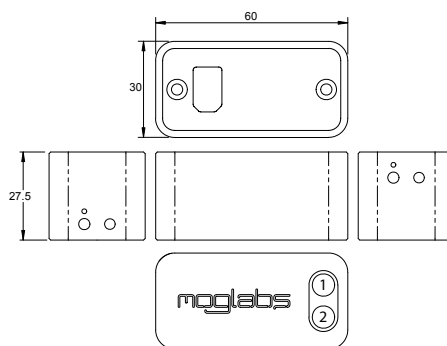

Figure H.2: M4 mounting holes are marked with a dimple; others are 8-32. Single channel photodiode 1, differential signal 1 – 2.

H.1 Photodiodes

The standard photodetector uses Si-PIN photodiodes encapsulated in a coloured plastic which transmits in the near-infrared and blocks most room light. The diodes include a lens to reduce the acceptance angle to $\pm 10^\circ$. Unfiltered diodes, and wider acceptance angles, are also available.

Photodiode Specifications		
Parameter	Standard	Options
Spectral range(10% of max)	750 – 1100 nm	400 – 1100 nm
Peak sensitivity	900 nm	850 nm
Half angle	$\pm 10^\circ$	$\pm 10^\circ, \pm 20^\circ, \pm 75^\circ$
Sensitive area	$1 \times 1 \text{ mm}^2$	
Max incident power	$500 \mu\text{W}$	
Apparent sensitivity (CHAN A)	$30 \text{ mV}/\mu\text{W}$	

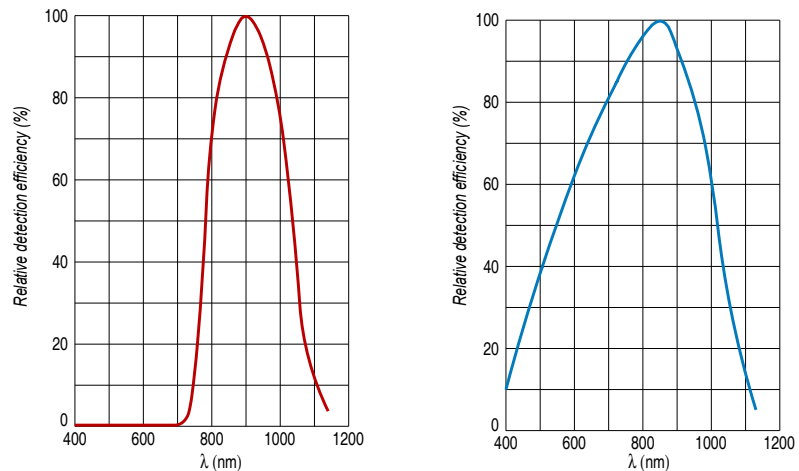

Figure H.3: Photodiode spectral response, standard filtered and unfiltered.

I. Laser head board

The laser head interface board provides connection breakout to the laser diode, TEC, sensor, piezo actuators, and laser head interlock. It also includes a protection relay and passive protection filters, a laser-on LED indicator, and an SMA connection for direct diode current modulation.

Several versions of the laser headboard are available. The default headboard provided with DLC controllers purchased without a laser is the rectangular B1040 or B1041, which uses Molex KK-100 connectors. The B1040/41 includes an RF bias tee allowing modulation up to 2.5 GHz, for example to add sidebands for repumping, or to add noise for coherence control.

MOGLabs lasers are built with a T-shaped headboard, using Hirose DF59 “swing-lock” wire-to-board connectors (Digikey H11958-ND and H11957CT-ND plug and crimp pin). The B1047 headboard provides high bandwidth active current modulation for wide bandwidth frequency stabilisation and linewidth narrowing, for example using a high finesse optical cavity or polarisation spectroscopy. Higher bandwidth is provided by the B1240 headboard which further increases bandwidth and reduces phase delay, to allow sub-Hz linewidth narrowing. The B1240 is limited to low compliance voltage laser diodes (red and infrared); the B1047 must be used for blue diodes. B1045 and B1046 headboards provide RF modulation via an RF bias tee allowing modulation up to 2.5 GHz, for example to add sidebands for repumping, or to add noise for coherence control.

In all cases, there is no provision for the internal photodiode in many consumer-grade laser diodes.

I.1 B1040/B1041 headboard

The B1040 and B1041 are small rectangular boards using Molex KK100 connectors, most suitable for home-built lasers. They provide connection to one or two piezos (slow high-range multi-layer stack and fast disc), and either passive NTC thermistor or active AD590/592 active temperature sensor. Only one temperature sensor should be connected, not both. Note that the MOGLabs DLC does not provide a mechanism for optical power control or measurement for diodes with an internal photodiode.

The B1040 and B1041 variants are equivalent, but the older B1040 has an extra SMA connector (P3) for high bandwidth RF connection to the laser diode.

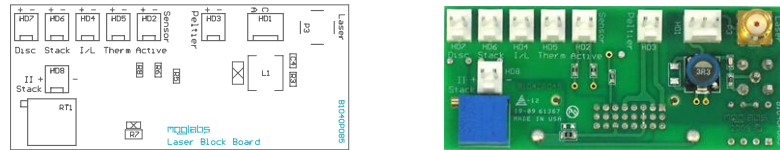

Figure I.1: MOGLabs DLC B1040/B1041 laser head board showing headers for connection of laser diode, piezo actuators, temperature sensor, TEC and head enclosure interlock. Connectors are Molex KK-100.

P1	Microwave RF modulation input (SMA)
P3	Diode (SMA, high bandwidth) B1041 only
HD1	Diode (MOLEX)
HD2	Active temperature sensor (AD590 or AD592)
HD3	Peltier TEC
HD4	Interlock; laser disabled unless short-circuited
HD5	Thermistor temperature sensor, 10 k Ω
HD6	Primary piezo STACK
HD7	Piezo DISC
HD8	Secondary piezo STACK

I.2 B1045/1046 headboard

The B1045 and B1046 provide connection to one or two piezos (slow high-range multi-layer stack and fast disc), and either passive NTC thermistor or active AD590/592 active temperature sensor. Note only one temperature sensor should be connected, not both. They provide an SMA input for direct diode modulation via an RF bias tee (see I.2.1 below).

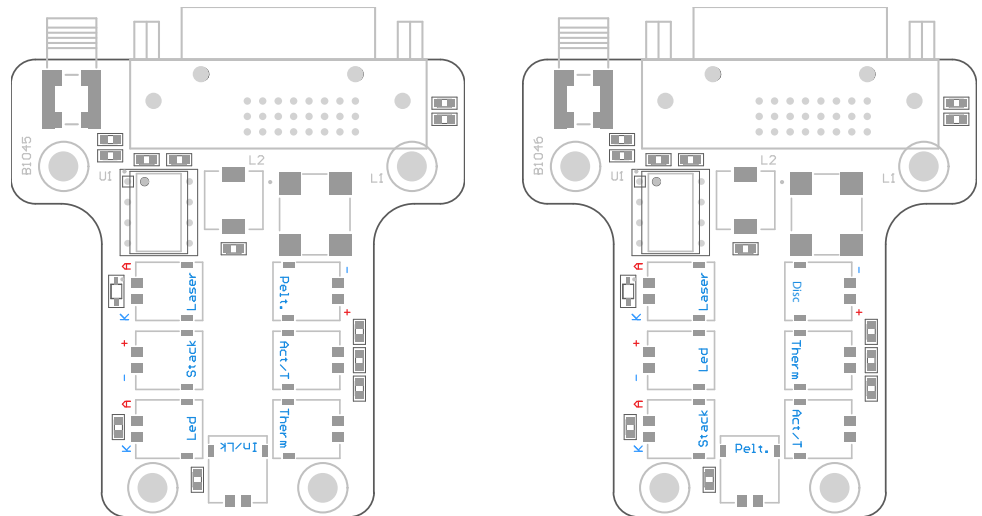

Figure I.2: MOGLabs B1045 and B1046 laser head boards showing connectors for laser diode, piezo actuator, temperature sensors, TEC and head enclosure interlock. Connectors are Hirose DF59.

I.2.1 RF coupling

For the B1045/1046 headboard, the SMA connector allows high-frequency current modulation via a bias-tee. The RF input is AC coupled, with low- and high- frequency limits of about 30 kHz and 2.5 GHz (see figure I.3). Capacitor C4, either 47 nF or 100 pF, can be changed to adjust the low-frequency cutoff. For higher bandwidths, use an external bias-tee such as the Mini-Circuits ZFBT-4R2GW-FT

between the head board and the diode.

The input impedance is $10\text{ k}\Omega$. The sensitivity depends on the diode impedance but is typically around 1 mA/V .

WARNING: The RF input is a direct connection to the laser diode. Excessive power can destroy the diode, which is separated from the head board relay by an inductor. Thus the relay does *not* provide protection from high frequency signals.

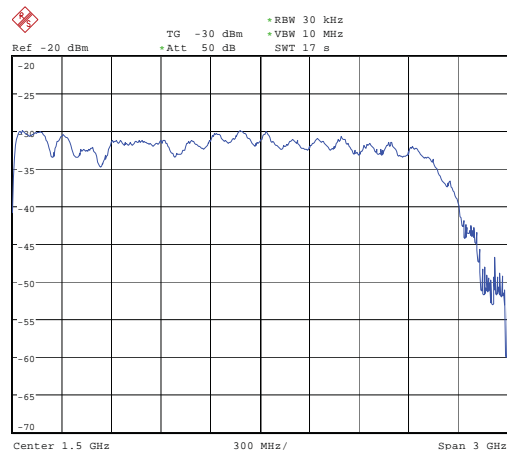

Figure I.3: RF response, SMA input on laser headboard to diode SMA output.

I.3 B1047/B1240 headboards

The B1047 and B1240 provide high-speed active modulation of the diode current. They use 500 MHz opamps and very low latency circuitry to reduce phase delay to around 12 ns for the B1240. The B1047 allows for closed-loop bandwidth of about 1.2 MHz while the B1240 can achieve about 4 MHz (in both cases, without phase advance), which is helpful in achieving sub-Hz linewidth reduction by locking to a high-finesse optical cavity. The B1240 also allows direct-ground connection or buffered; the latter is about 10% slower but reduces problems with ground-loop noise. The B1240 is not suitable for diodes with high compliance voltage, typically diodes with wavelength below 600 nm.

Note that connection to the SMA input will reduce the diode current, even if the control voltage is at zero.



Figure I.4: B1047 (left) and B1240 (right) enhanced laser head boards. Jumpers at top left can be configured for AC or DC coupling. The B1240 has an additional jumper “Buf Dir” for buffered or direct input, shown connected for buffered; change to pins 1 and 2 for direct. Modulation input via SMA connector, sensitivity 2.5 mA/V. Connectors are Hirose DF59.

I.3.1 SMA input

The B1047/B1240 SMA input provides AC or DC coupling to an active modulation circuit. Note that connection to the SMA input will reduce the diode current by about 1.6 mA (B1047) to 2.5 mA (B1240), with zero input voltage.

	B1047	B1240
Input range	± 2.0 V max	± 2.0 V max
Input coupling	AC/DC	DC (direct) AC/DC (buffered)
AC time constant	15 μ s (10 kHz)	15 μ s (10 kHz)
Phase delay	40 ns	< 20 ns (direct) < 30 ns (buffered)
Gain bandwidth (-3 dB)	3 MHz	20 MHz
Input impedance	5 k Ω	AC buffered: 1 k Ω at 10 kHz DC buffered: 1 k Ω Direct: 1 k Ω
Current gain	1 mA/V	1 mA/V
Laser diode voltage	10 V max	2.5 V max

I.4 Headboard connection to controller

Note

The MOGLabs laser cable is a digital DVI-D DL (**dual link**) cable. There is a bewildering assortment of apparently similar cables available. Most *computer display* DVI cables will **not** work because they are missing important pins; see diagram below. Only high quality digital **dual-link** DVI-D DL cables should be used.

Pin	Signal	Pin	Signal	Pin	Signal
1	TEC -	9	DIODE -	17	DISC +
2	TEC +	10	DIODE +	18	DISC -
3	Shield	11	Shield	19	Shield
4	TEC -	12	DIODE -	20	STACK +
5	TEC +	13	DIODE +	21	STACK -
6	T_{sense} -	14	Relay GND	22	
7	T_{sense} +	15	+5V in	23	NTC -
8		16	Interlock out	24	NTC +

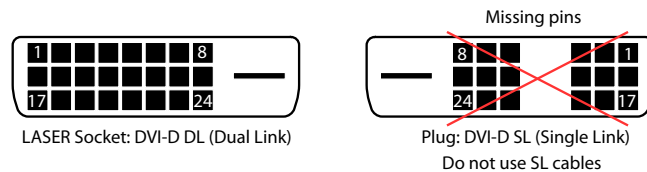

Figure I.5: Headboard connector. Note that the pinout is different to that of the matching connector on the rear of the DLC controller.

A 10 k thermistor (typically EPCOS B57861S0103F040, $\beta = 3988$) should be connected to NTC+ and NTC-, but an AD590 or AD592 temperature sensor can be instead be connected to T_{sense} . Pin 15 should be connected to a +5V supply. To activate the laser diode, relay GND (pin 14) should be grounded to open the relay that otherwise short-circuits the diode current. +5V (pin 15) is internally connected to pin 16 (Interlock), normally with a permanent connection but on some headboards (see above), a connector is provided to allow connection to a cover-activated microswitch to disable the laser

when the cover is removed.

I.5 Dual piezo operation

The DLC provides outputs to two piezo elements. They can be configured as:

Single Typically, only a single “stack” actuator, such as the Tokin AE0203D04 (available from Thorlabs, www.thorlabs.com), will be required. The single stack actuator allows frequency scanning and frequency offset selection, and active slow feedback (up to ≈ 100 Hz). Connect STACK to **HD6** (sometimes labelled Stk_1 on the headboard).

Two channel The DLC feedback servos include a second channel for high-speed piezo feedback, typically to a disc actuator. This would be connected to **HD7** (Stk.2 or Piezo 2).

Since DLC revision 9.01, this second feedback channel is disconnected and instead both piezo outputs are driven in parallel, with a variable relative gain adjusted by RT7 (near the DIP switches). If there is a failure of the STACK electronic driver, it is possible to use the DISC driver; simply connect the STACK to **HD7** (Stk.2).

Alternate single channel For older controllers, to change to the alternate high voltage driver, make the following modifications on the DLC main board, referring to appendix L for component locations:

- Insert a 0R0 resistor, size 0603, for R602
- Remove R601 (nominally 10R0)
- Change R372 from 30k0 (size 1206) to 270k (STACK at 120 V) or 390k (STACK at 150 V) (see LK2, p.15).
- Adjust RT7 fully clockwise.

On the laser headboard, connect the STACK piezo actuator to HD7 (Stk_2 or Piezo 2).

Parallel The DISC channel can instead be used to drive a second STACK actuator, for example to allow simultaneous translation and tilt of a diffraction grating, to increase the mode-hop free tuning range. Connect the second piezo to HD7 and adjust RT7 to vary the relationship of the potential to the second piezo from 0.3 to 1.0 times the potential on the main STACK.

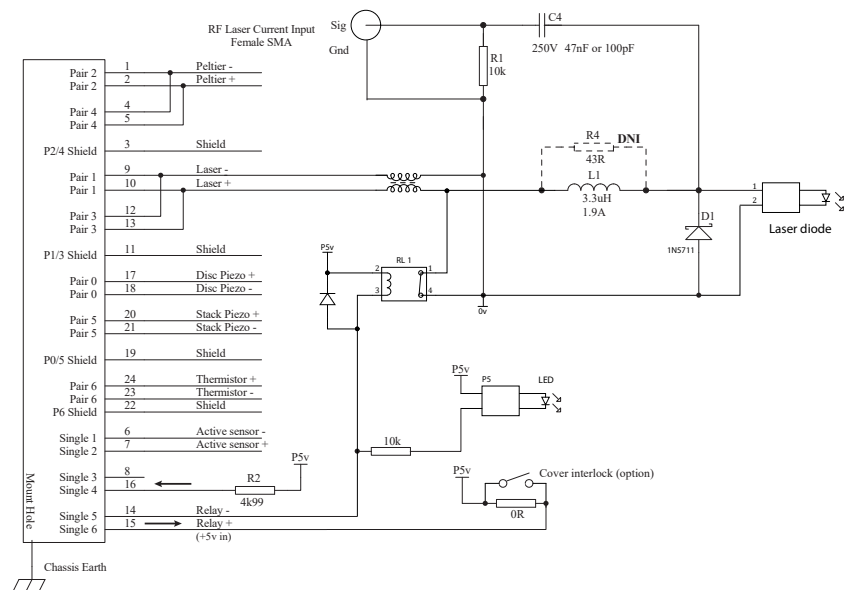

Figure I.6: MOGLabs DLC laser head board schematic (B1040/1045). The RF modulation low-pass cutoff frequency is determined by C4 and the diode impedance ($\sim 50\Omega$).

J. Control overview

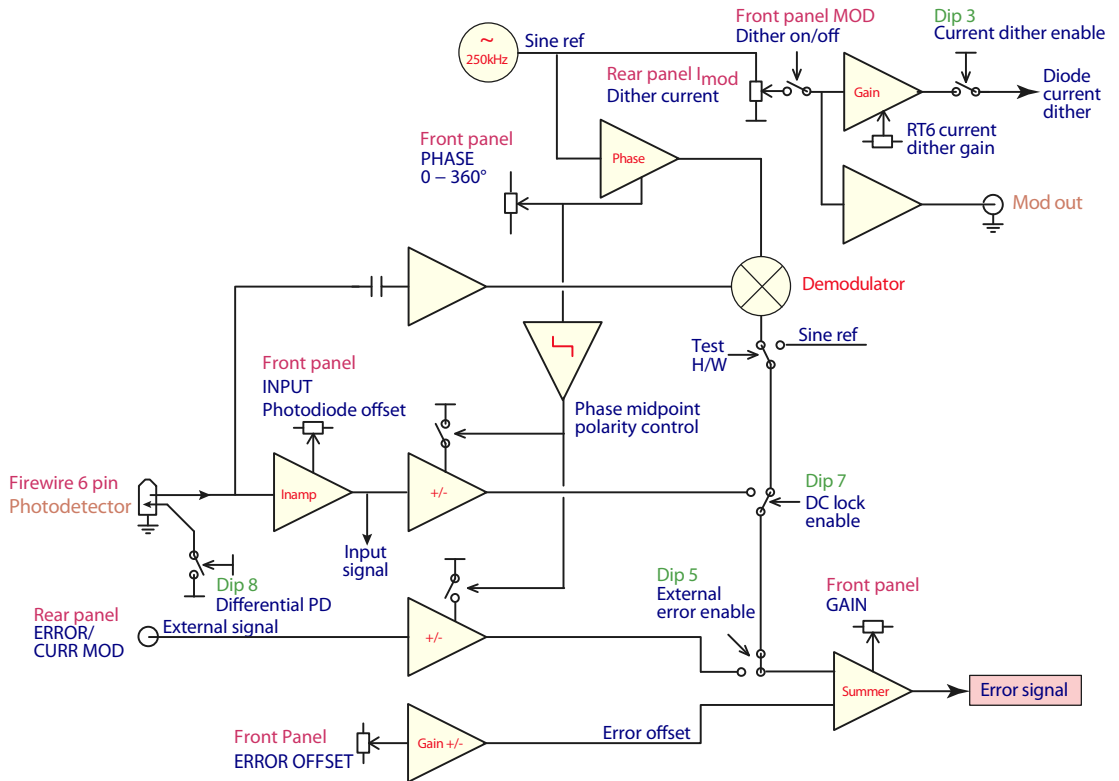

Figure J.1: Overview of error and control signals.

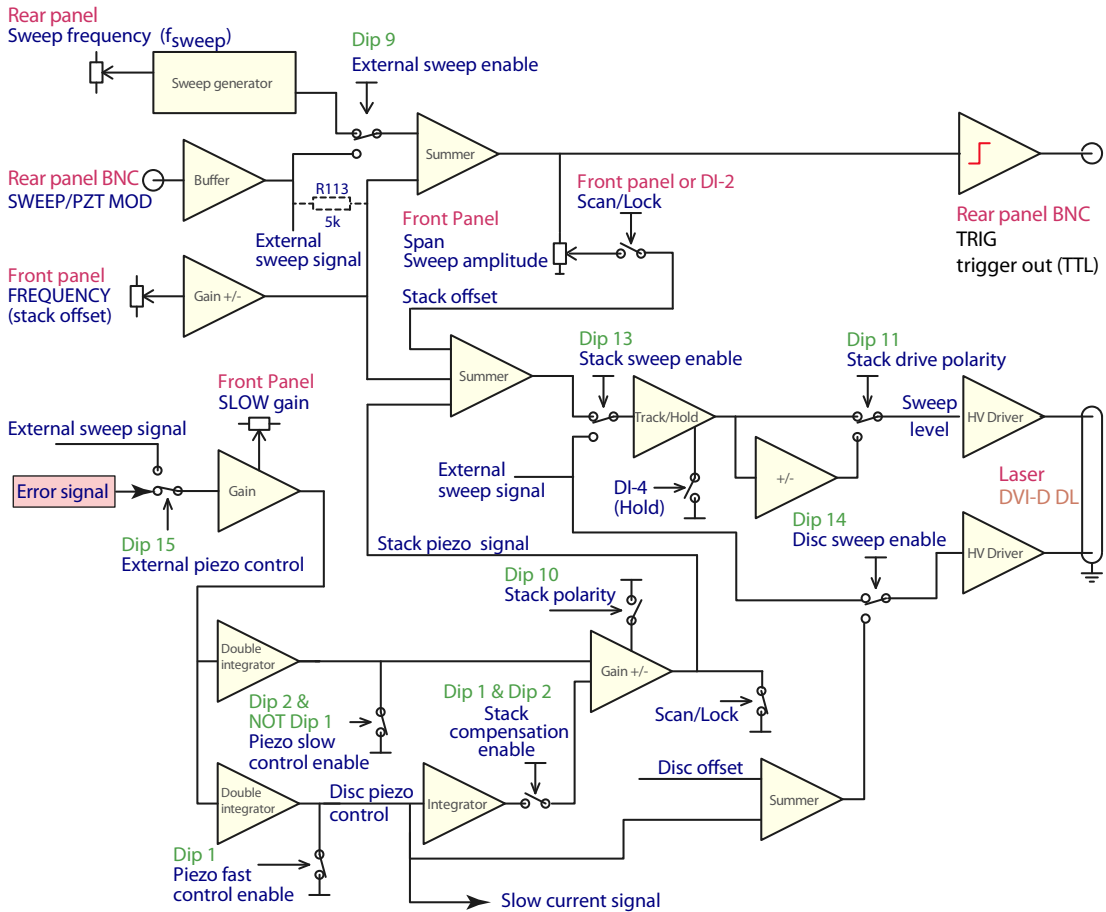

Figure J.2: Overview of slow feedback and piezo signals. Resistor R113 is not installed by default.

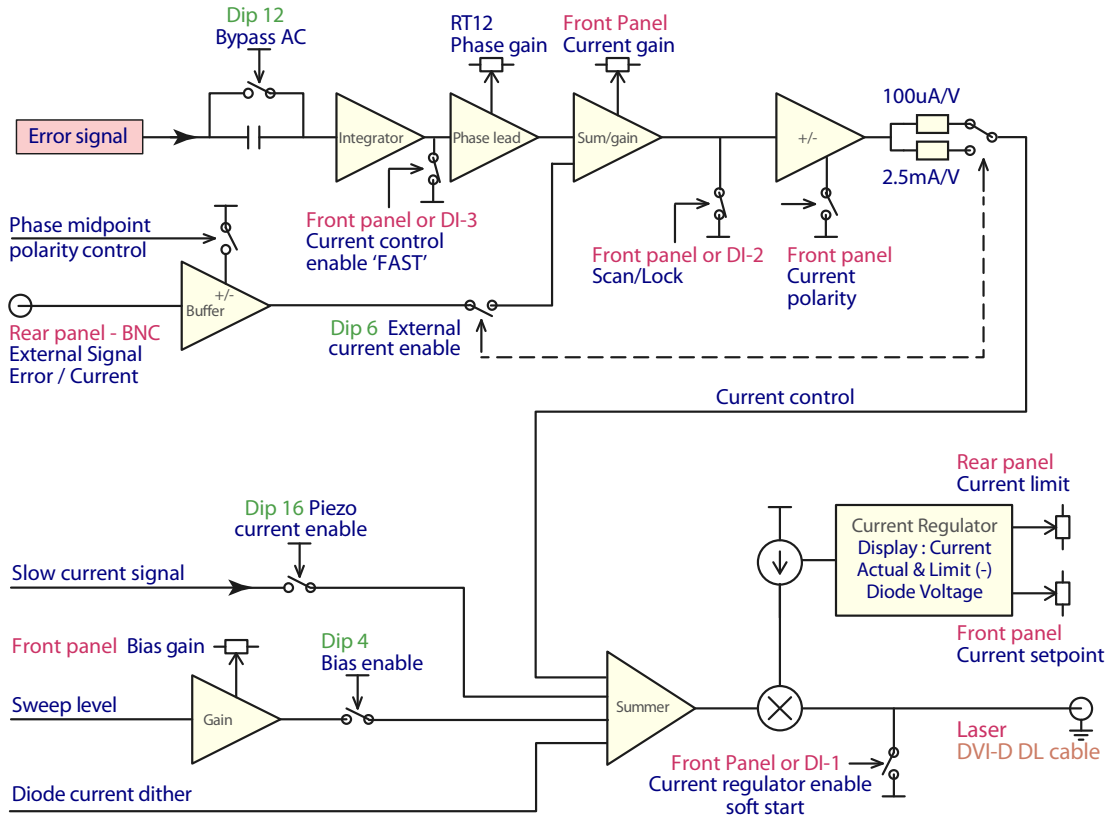

Figure J.3: Overview of fast feedback and diode current signals.

K. Connectors and cables

K.1 LASER

WARNING

The LASER connector should only be connected to a MOGLabs laser or laser head board. High voltages are present on some pins. The supplies will be disabled if the cable is disconnected, but nevertheless considerable care should be taken to ensure non-MOGLabs devices are not connected.

Note

Most computer display DVI cables will **not** work. They are missing important pins; see diagram below. Only high quality digital **dual-link** DVI-D DL cables should be used.

Pin	Signal	Pin	Signal	Pin	Signal
1	TEC -	9	DIODE -	17	DISC +
2	TEC +	10	DIODE +	18	DISC -
3	Shield	11	Shield	19	Shield
4	TEC -	12	DIODE -	20	STACK +
5	TEC +	13	DIODE +	21	STACK -
6	$T_{sense} -$	14	Relay GND	22	
7	$T_{sense} +$	15	+5V out	23	NTC -
8		16	Interlock in	24	NTC +

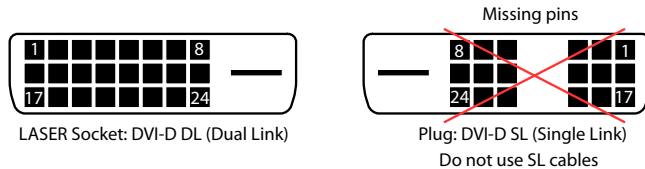

Figure K.1: LASER connector on rear panel of DLC, and plug of common display cable, unsuitable for use with DLC due to missing connections.

A 10k thermistor should be connected to NTC+ and NTC-, but an AD590 or AD592 temperature sensor can be instead be connected to T_{sense} . Pin 15 provides +5V. Relay GND (pin 14) is grounded when the laser diode is activated, to open the relay that otherwise short-circuits the laser diode. +5V should be supplied to pin 16 (Interlock), for example from pin 15, to signal that the interlock is shorted.

K.2 Photodetector

The photodetector is connected via standard 6-pin IEEE-1394 (FireWire) connectors. Note that firewire cables swap pins 3,4 with pins 5,6 so the pinout on the photodetector connector is different to that on the controller.

Pin	Controller	Detector
1	Ground	
2	Differential if GND	
3	+12V	Signal -
4	-12V	Signal +
5	Signal -	+12V
6	Signal +	-12V

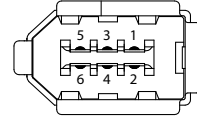

Figure K.2: PHOTODETECTOR connector on rear panel of DLC and corresponding connector on photodetector. Differential output is enabled if pin 2 is grounded (0V). Single-ended is open-circuit or high (+12V). Note that firewire cables swap pins 3,4 with 5,6.

K.3 Interlock

The rear-panel interlock socket is a standard 2.1 mm cylindrical DC power jack. The outer conductor is supplied with 5V via a 5k resistor. The inner pin is connected to ground via a 10k resistor. The laser should be enabled by shorting the two contacts.

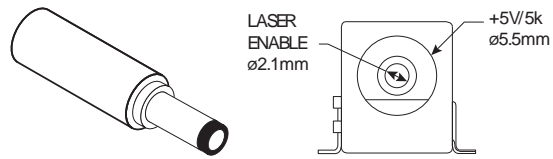

Figure K.3: INTERLOCK connector on rear panel.

K.4 Digital control

HD12 is a 10-pin header which provides access to several important control signals for locking and for sample-and-hold of the lock-point, as described in section 2.6. The signals are standard TTL-compatible, $> 2.4\text{ V}$ HIGH and $< 0.8\text{ V}$ LOW. The inputs are ORed with the front toggle-switches, such that the signal is activated if either the digital input is active (i.e. HIGH) or the toggle switch is on (down).

Pin	Signal	Pin	
1	Laser ON/OFF	2	GND
3	Lock/Sweep	4	GND
5	Fast Lock	6	GND
7	Hold	8	GND
9	+5V	10	GND

M. 115/230 V conversion

M.1 Fuse

The fuse is a ceramic antisurge, 2.5A, 5x20mm, for example Littlefuse 021502.5MXP. The fuse holder is a red cartridge just above the IEC power inlet and main switch on the rear of the unit (Fig. M.1).



Figure M.1: Fuse cartridge, showing fuse placement for operation at 230Vac.

M.2 120/240 V conversion

The controller can be powered from AC 50 to 60 Hz, 110 to 120 V (100 V in Japan), or 220 to 240 V. To convert between 115 V and 230 V, the fuse cartridge should be removed, and re-inserted such that the correct voltage shows through the cover window.



Figure M.2: To change fuse or voltage, open the fuse cartridge cover with a screwdriver inserted into a small slot at the top of the cover, just above the red voltage indicator.

When removing the fuse cartridge, insert a screwdriver into the recess at the *top* of the cartridge; do not try to extract using a screwdriver at the sides of the fuseholder (see figures).



Figure M.3: To extract the fuse cartridge, insert a screwdriver into a recess at the *top* of the cartridge.

When changing the voltage, the fuse and a bridging clip must be swapped from one side to the other, so that the bridging clip is always on the left and the fuse always on the right; see figures below.

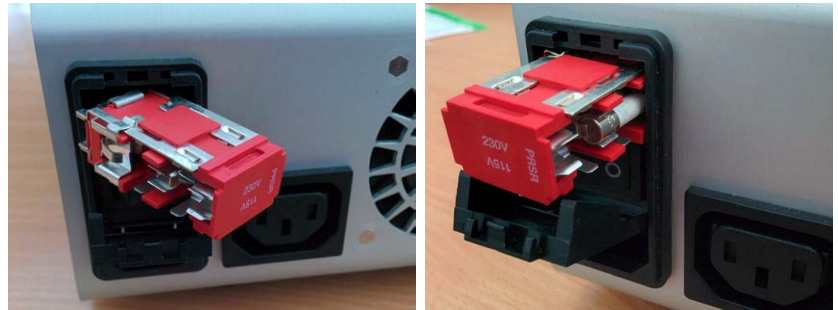

Figure M.4: Bridge (left) and fuse (right) for 230V. Swap the bridge and fuse when changing voltage, so that the fuse remains on the right-hand side (see below).

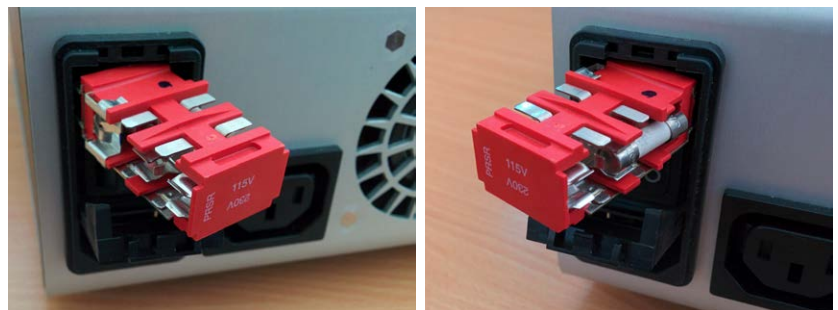

Figure M.5: Bridge (left) and fuse (right) for 115V.

Bibliography

- [1] C. J. Hawthorn, K. P. Weber, and R. E. Scholten. Littrow configuration tunable external cavity diode laser with fixed direction output beam. *Rev. Sci. Inst.*, 72(2):4477, 2001. i
- [2] L. Ricci, M. Weidemüller, T. Esslinger, A. Hemmerich, C. Zimmermann, V. Vuletic, W. König, and T. W. Hänsch. A compact grating-stabilized diode laser system for atomic physics. *Opt. Communic.*, 117:541, 1995. i
- [3] S. D. Saliba, M. Junker, L. D. Turner, and R. E. Scholten. Mode stability of external cavity diode lasers. *Appl. Opt.*, 48(35):6692, 2009. i, 59, 60
- [4] S. D. Saliba and R. E. Scholten. Linewidths below 100 khz with external cavity diode lasers. *Appl. Opt.*, 48(36):6961, 2009. i
- [5] W. Demtröder. *Laser Spectroscopy, Basic Concepts and Instrumentation*. Springer, Berlin, 2e edition, 1996. 4, 39
- [6] H. A. Wheeler. Simple inductance formulas for radio coils. *Proc. I. R. E.*, 16:1398, 1928. 70
- [7] S. C. Bell, D. M. Heywood, J. D. White, and R. E. Scholten. Laser frequency offset locking using electromagnetically induced transparency. *Appl. Phys. Lett.*, 90:171120, 2007. 76
- [8] G. C. Bjorklund. Frequency-modulation spectroscopy: a new method for measuring weak absorptions and dispersions. *Opt. Lett.*, 5:15, 1980. 76, 77
- [9] R. W. P. Drever, J. L. Hall, F. V. Kowalski, J. Hough, G. M. Ford, A. J. Munley, and H. Ward. Laser phase and frequency stabilization using an optical resonator. *Appl. Phys. B*, 31:97–105, 1983. 76, 77

