

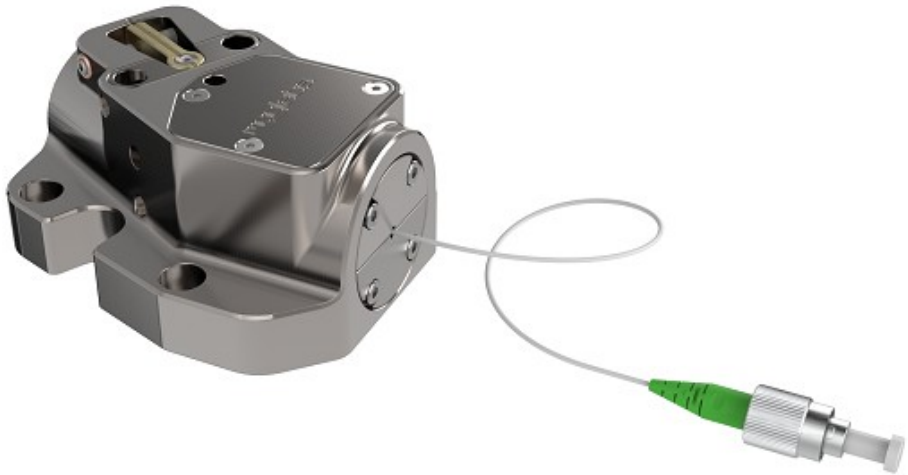

External Cavity SAF Laser

CES Cateye



Revision 1.02

Limitation of Liability

MOG Laboratories Pty Ltd (MOGLabs) does not assume any liability arising out of the use of the information contained within this manual. This document may contain or reference information and products protected by copyrights or patents and does not convey any license under the patent rights of MOGLabs, nor the rights of others. MOGLabs will not be liable for any defect in hardware or software or loss or inadequacy of data of any kind, or for any direct, indirect, incidental, or consequential damages in connections with or arising out of the performance or use of any of its products. The foregoing limitation of liability shall be equally applicable to any service provided by MOGLabs.

Copyright

Copyright © MOG Laboratories Pty Ltd (MOGLabs) 2014 – 2025. No part of this publication may be reproduced, stored in a retrieval system, or transmitted, in any form or by any means, electronic, mechanical, photocopying or otherwise, without the prior written permission of MOGLabs.

Contact

For further information, please contact:

MOG Laboratories P/L
49 University St
Carlton VIC 3053
AUSTRALIA
+61 3 9939 0677
info@moglabs.com
www.moglabs.com

Santec LIS Corporation
5823 Ohkusa-Nenjozaka, Komaki
Aichi 485-0802
JAPAN
+81 568 79 3535
www.santec.com

Preface

Diode lasers can be wonderful things: they are efficient, compact, low cost, high power, low noise, tunable, and cover a large range of wavelengths. They can also be obstreperous, sensitive, and temperamental, particularly external cavity diode lasers (ECDLs). In combination with advanced electronics such as the MOGLabs DLC external cavity diode laser controller, the CES cateye laser described here provides a robust, stable, acoustically inert, low linewidth and highly tunable laser system.

We hope that the MOGLabs CES works well for your application. Please let us know if you have any suggestions for improvement in the laser or in this document, so that we can make life in the laser lab easier for all, and check our website from time to time for updated information.

MOGLabs, Melbourne, Australia
www.moglabs.com

Safety Precautions

Safe and effective use of this product is very important. Please read the following laser safety information before attempting to operate the laser. Also please note several specific and unusual cautionary notes before using MOGLabs lasers, in addition to the safety precautions that are standard for any electronic equipment or for laser-related instrumentation.

CAUTION – USE OF CONTROLS OR ADJUSTMENTS OR PERFORMANCE OF PROCEDURES OTHER THAN THOSE SPECIFIED HEREIN MAY RESULT IN HAZARDOUS RADIATION EXPOSURE

Laser output from the CES can be dangerous. Please ensure that you implement the appropriate hazard minimisations for your environment, such as laser safety goggles, beam blocks, and door interlocks. MOGLabs takes no responsibility for safe configuration and use of the laser. Please:

- Avoid direct exposure to the beam.
- Avoid looking directly into the beam.
- Note the safety labels (examples shown in figure below) and heed their warnings.
- When the laser is switched on, there will be a short delay of two seconds before the emission of laser radiation, mandated by European laser safety regulations (IEC 60825-1).
- The STANDBY/RUN keyswitch must be turned to RUN before the laser can be switched on. The laser will not operate if the keyswitch is in the STANDBY position. The key cannot be removed from the controller when it is in the clockwise (RUN) position.

- To completely shut off power to the unit, turn the keyswitch anti-clockwise (STANDBY position), switch the mains power switch at rear of unit to OFF, and unplug the unit.
- When the STANDBY/RUN keyswitch is on STANDBY, there cannot be power to the laser diode, but power is still being supplied to the laser head for temperature control.

WARNING The internal circuit board and piezoelectric transducers are at high voltage during operation. The unit should not be operated with covers removed.

WARNING The laser chassis should be in good electrical contact to the optical table or other surface, which in turn should be connected to the same mains power supply electrical ground as the controller.

CAUTION Although the CES is designed and priced with the expectation that the end-user can replace the diode and change the alignment, some components are fragile. In particular the filter, piezo actuator, and mirror are very easily damaged. Please take care of these items when working inside the laser.

The filter and mirror are hard-coated and can be cleaned but great care is needed as with any intracavity laser optics.

NOTE MOGLabs products are designed for use in scientific research laboratories. They should not be used for consumer or medical applications.

Label identification

The International Electrotechnical Commission laser safety standard IEC 60825-1:2007 mandates warning labels that provide information on the wavelength and power of emitted laser radiation, and which show the aperture where laser radiation is emitted. Figure 1 shows examples of these labels, and figure 2 shows their location on the CES laser.

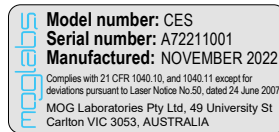

US FDA compliance

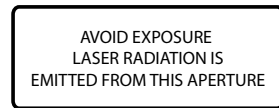

Aperture label engraving

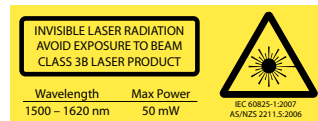

Warning and advisory label
Class 3B

Figure 1: Warning advisory and US FDA compliance labels.

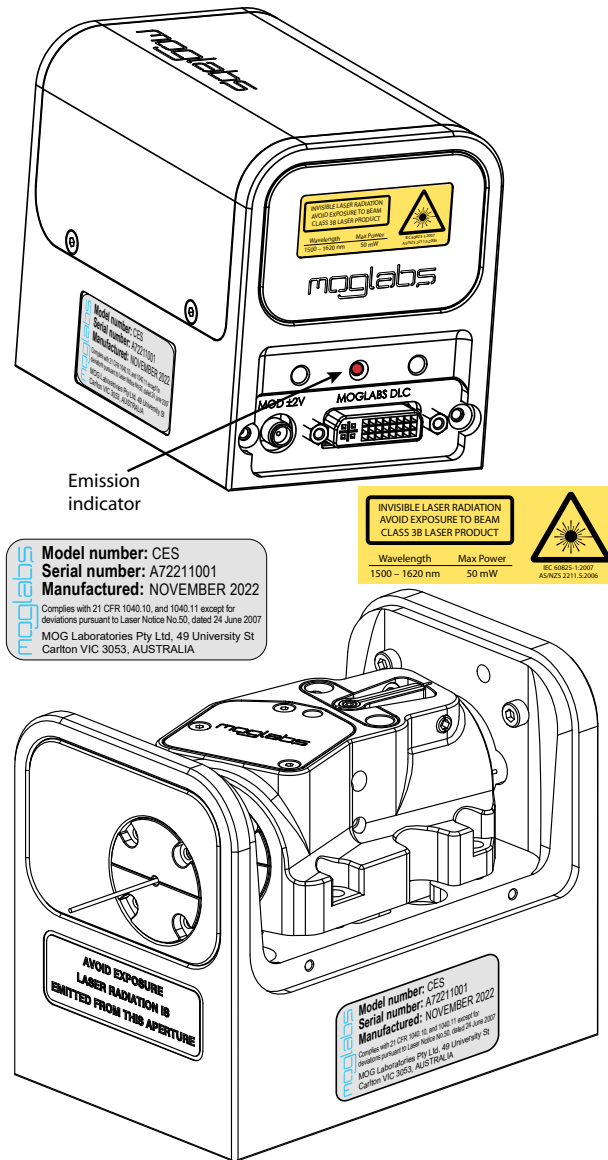

Figure 2: Schematic showing location of laser warning labels compliant with International Electrotechnical Commission standard IEC 60825-1:2007, and US FDA compliance label. Aperture label engraved on the front of the CES laser near the exit fibre; warning advisory label on the rear and compliance label on side.

Protection Features

MOGLabs lasers includes a number of features to protect you and your laser.

Protection relay When the power is off, or if the laser is off, the laser diode is shorted via a normally-closed solid-state relay at the laser head board.

Emission indicator The MOGLabs controller will illuminate the emission warning indicator LED immediately when the laser is switched on. There will then be a delay of at least 2 seconds before actual laser emission.

Interlock It is assumed that the laser power supply is keyed and interlocked for safety. The laser head board also provides connection for an interlock (see appendix B), if used with a power supply which does not include such an interlock.

RoHS Certification of Conformance

MOG Laboratories Pty Ltd certifies that the MOGLabs External Cavity Diode Laser does not fall under the scope defined in *RoHS Directive 2002/95/EC*, and is not subject to compliance, in accordance with *DIRECTIVE 2002/95/EC Out of Scope; Electronics related; Intended application is for Monitoring and Control or Medical Instrumentation*.

MOG Laboratories Pty Ltd makes no claims or inferences of the compliance status of its products if used other than for their intended purpose.

Extending laser diode and piezo lifetime

At night, switch to standby:

1. If using the CES to seed an amplifier, first turn off the amplifier.
2. Switch the laser diode current off.
If using a MOGLabs DLC controller, don't adjust the current, just switch the toggle up (off).
3. Switch from RUN to STANDBY.

For a MOGLabs DLC controller in standby mode, the temperature controller will continue to operate, so the laser is ready for quick startup the next day. But the laser diode current and piezo voltage will be zero, extending their operating life.

In the morning, switch back on:

1. Switch from STANDBY to RUN.
2. Switch the laser diode toggle down (on).
You don't need to adjust the current, just wait a few minutes for the diode temperature to equilibrate.

You should switch your MOGLabs DLC into STANDBY mode at nights and weekends and whenever the laser is not being used for more than a few hours. Many lasers tend to operate only 40 hours during a 168 hour week; thus switching to standby mode can extend the diode and piezo lifetime by a factor of four.

Contents

Preface	i
Safety	iii
Protection features	vii
RoHS Certification of Conformance	viii
Extending laser diode & piezo lifetime	ix
1 Introduction	1
1.1 External cavity	2
1.2 Piezo-electric frequency control	3
1.3 Temperature and current	3
2 First light	5
2.1 Standby/Run	5
2.2 Current	6
2.3 Temperature	7
3 Operation	9
3.1 Power	9
3.2 Wavelength	9
3.3 Mode-hops	10
3.4 Scanning	11
4 Troubleshooting	13
4.1 Scanning adjustment	13
4.1.1 BIAS optimisation	14
4.2 Filter adjustment	16
4.3 Threshold optimisation	17

A Specifications	21
A.1 CES mechanical	23
B Laser head electronics	25
B.1 SMA input	26
B.2 Headboard connection to controller	27
References	29

1. Introduction

Semiconductor laser diodes are compact, efficient and low-cost, but usually have poor wavelength control, linewidth and stability. The addition of an external frequency-selective cavity allows control of the operating wavelength over a few nm range, with sub-MHz linewidth and stability. The MOGLabs CES (see Fig. 1.1) is machined from a solid aluminium block, so that the laser is stable, robust, and insensitive to acoustic disturbances. The cavity is hermetically sealed for additional suppression of environmental fluctuations and drift.

The MOGLabs CES is a “cat-eye” design (see Fig. 1.2), in which an external cavity is formed between the exit surface of the semiconductor diode and a cat-eye reflector at several centimetres from the rear of the diode [1–3]. Rather than the customary diffraction grating of Littrow-configuration ECDLs, a high efficiency ultranarrow filter is used to select a single external cavity mode. Without the need for illuminating a large area of a grating for feedback, a cat-eye retroreflector can be used to form the external

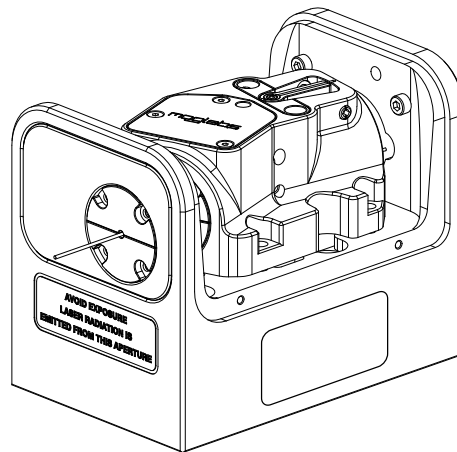

Figure 1.1: The MOGLabs CES cateye laser.

cavity. The cateye reflector is inherently self-aligning, so that the laser is extremely insensitive to mechanical disturbance, and also ensures high feedback coupling efficiency and consequently narrow linewidth.

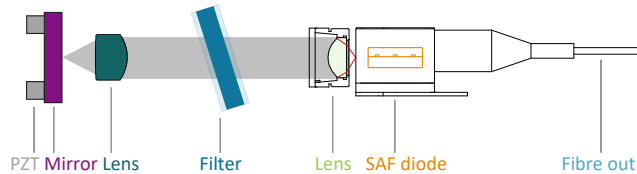

Figure 1.2: Schematic of the cateye external cavity diode laser (ECDL) using single-angled facet (SAF) diode. The external cavity is formed between the facet of the laser diode at the output (fibre) end, and the mirror. One longitudinal cavity mode is selected by an ultranarrow intracavity bandpass filter. A cateye reflector is formed by the piezo-mounted mirror and intracavity lens.

The output beam from the rear facet of a laser diode is collimated with a high numerical aperture lens and incident on the filter. The filter transmission wavelength depends on the rotation angle. Transmitted light is back-reflected by the cateye lens/mirror combination which efficiently couples light back into the laser diode. More details can be found in references [1–3]. The usable output is directly and permanently coupled at the front diode facet to a polarisation-maintaining fibre with FC/APC connector at the output.

1.1 External cavity

Semiconductor laser diodes normally have a high reflectivity rear facet and a front facet with reflectivity of only a few percent. The diode cavity is called the intrinsic or internal cavity. The *external* cavity is formed by the mirror and the diode rear facet, and when the external feedback is greater than that of the front facet, the external cavity determines the lasing wavelength. The external cavity is typically about 40 mm long from rear facet of semiconductor to mirror, giving a cavity mode spacing determined by the free spectral range $FSR = c/2L = 4 \text{ GHz}$.

The laser diode is butterfly-mounted and fixed to the laser barrel. The

collimating lens is rigidly held in a focusing tube, itself mounted in an $x - y$ translation stage. The filter is fixed to a bearing-mounted rotation assembly with a fine thread screw to adjust the angle. The wavelength adjuster is opposed by a spring-loaded screw, and the two can be locked against each other to further reduce the effects of mechanical vibration. The filter angle is used for coarse wavelength and mode selection, within the gain bandwidth of the laser diode.

1.2 Piezo-electric frequency control

Small changes to the laser frequency are achieved by controlling the external cavity length with a piezo electric actuator. For the MOGLabs CES, the frequency change is about 20 GHz over the full 150 V range of the piezo. The bandwidth is limited by mechanical resonances, typically 25 kHz.

1.3 Temperature and current

The laser frequency is also dependent on temperature and injection current; the sensitivities are typically 3 MHz/ μ A and 30 GHz/K [4]. Thus, low-noise stable electronics, such as the MOGLabs DLC external cavity diode laser controller, are essential (see Ref. [5]) to achieve sub-MHz linewidth and stability.

An important aspect of an ECDL is temperature control of the cavity, since the laser frequency depends on the cavity length and hence on the thermal expansion coefficient of the cavity material [6]. The cavity can be machined from materials with low thermal expansion coefficient but even then the passive stability is inadequate for research applications. Active feedback of the cavity temperature and piezo cavity length provide flexible and stable control. The MOGLabs CES uses a negative temperature coefficient (NTC) thermistor to sense the cavity temperature and Peltier thermoelectric cooler (TEC) to heat and cool the cavity material.

2. First light

The MOGLabs CES laser has a fibre output permanently attached. Great care should be taken when handling the laser and being mindful of stresses applied to the fibre (e.g. bending at tight radii, clamping), stresses applied to the rubber boot connecting the fibre to the butterfly mount and contamination of the FC/APC connector end where the fibre is exposed.

Mount your laser to an optical table using the screws provided. Your laser has been carefully tuned to the specifications given in your laser test report. Please make sure as you continue with this manual, that the diode injection current, temperature and piezo offset (FREQUENCY) match those of the test report.

The laser chassis should be in good electrical contact to the optical table or other surface, which in turn should be connected to the same mains power supply electrical ground as the controller.

It is assumed that a MOGLabs DLC controller has been provided with your laser. If a third party controller is used, please set a current limit according to the maximum safe operating current stipulated in your test report.

For longer wavelength lasers, an IR upconversion card or CCD camera without IR filter can be very helpful. Common low-cost security cameras, computer USB cameras, and home movie or still cameras are also good options, although they often have infra red filters which may need to be removed.

2.1 Standby/Run

Please first check that the MOGLabs DLC has been set to the correct mains supply voltage by inspecting the red voltage selector above the rear panel IEC power inlet. Then turn the main power switch on. Check the DLC internal DIP switches match the laser test report specification. Make sure that the laser diode current supply (CURRENT knob) is turned fully anti-

clockwise, and that the OFF/MOD, SLOW and FAST lock switches are off (up), and then turn the keyswitch from STANDBY to RUN. The LED status indicator should be yellow indicating that the thermistor and TEC elements are connected.

2.2 Current

Turn the laser diode CURRENT adjust to zero (fully anti-clockwise). Note that it is not recommended to turn the current to zero when turning off the laser: the soft-start function of the DLC ensures that the current is ramped up slowly and safely to the required current. When first aligning the laser to your experiment, it is important to set the laser output power to a low value for safety.

The usable output is directly and permanently coupled at the front diode facet to a polarisation-maintaining fibre with FC/APC connector at the output. To measure the power output, use a power meter and sensor with a suitable fibre connector adapter, preferably an integrating sphere type sensor to avoid the saturation typically observed with Si photodiode based sensors and small spot sizes.

Adjust the diode current to 5 – 10 mA and check that the diode voltage (VOLTAGE selection on main control knob on DLC) is the same as listed in the diode data sheet. If in doubt, please contact MOGLabs before continuing.

The laser threshold current is defined as the current at which the output is 1 mW. Adjust CURRENT to achieve 1 mW output, and if the threshold differs from that in the test report by more than 10 mA please refer to section 4.3.

Above threshold, the laser power vs. injection current is well approximated by a linear curve function (see figure 2.1). Initially the current should be set above threshold, but well below the maximum operating current, until the laser is fully aligned with your experiment.

2.3 Temperature

The optimum temperature has been set by MOGLabs and should not require adjustment. Once the diode current is set, allow 5 minutes for the temperature to reach equilibrium. When the laser is not needed for extended periods, for example overnight, turn the laser diode off and the keyswitch to STANDBY. In standby mode, the temperature controller remains active, so that stable operation can be achieved more quickly than when the DLC is powered off. It is not necessary to change the CURRENT setting when turning the laser diode on and off.

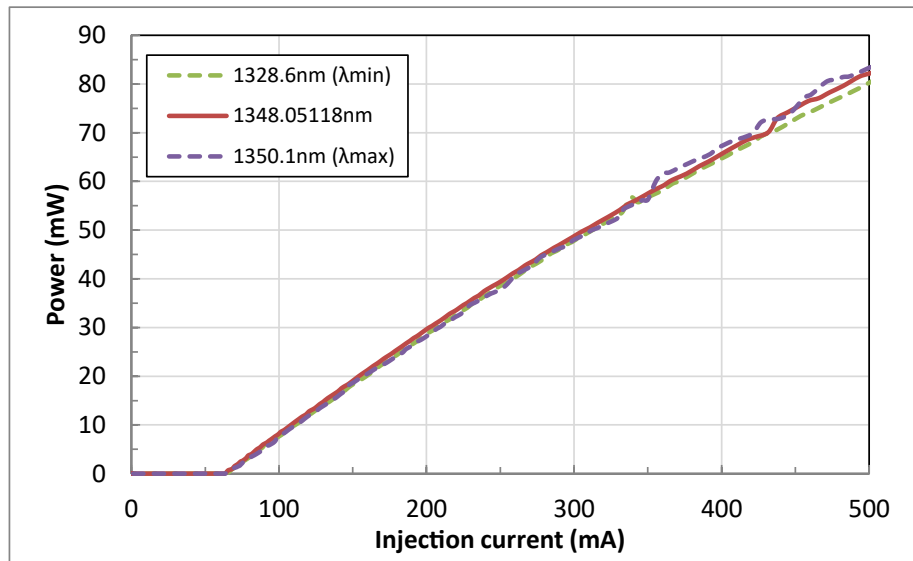

Figure 2.1: Sample laser diode power-current characteristic curves.

3. Operation

Your laser has been carefully tuned to the specifications provided in the laser test report. In most cases, the laser will perform as expected once the current, temperature and piezo settings are adjusted to those in the test report.

3.1 Power

Adjust CURRENT and compare the output power from the fibre to the laser power vs. injection current curve provided on the first page of your laser test report. Use a power meter and sensor with a suitable fibre connector adapter, preferably an integrating sphere type sensor to avoid the saturation typically observed with Si photodiode based sensors and small spot sizes. The threshold current and slope above threshold should be similar; if not, refer to section 4.3.

3.2 Wavelength

Once the power measured is comparable with the test report, the wavelength can be adjusted with reference to a wavemeter or spectrometer. Increase CURRENT to the value recorded in the laser test report. If the measured wavelength is within 0.1 nm of the desired wavelength, the current and piezo (FREQUENCY) can be used to make small changes. If the precise wavelength cannot be reached with current and piezo adjustments, then the wavelength should be adjusted using the λ adjustment screw (see figure 3.1). Ensure that the spring plunger is not locked against the arm of the filter spindle. For larger wavelength changes, release the spindle-clamp lock screw, then rotate the filter spindle and re-clamp.

Note that the cateye lens focus is wavelength dependent, so whenever the laser wavelength is changed substantially (more than say 5-10 nm), we recommend also optimising the feedback from the output coupler to reduce the current threshold at your new operating wavelength (see sec. 4.3).

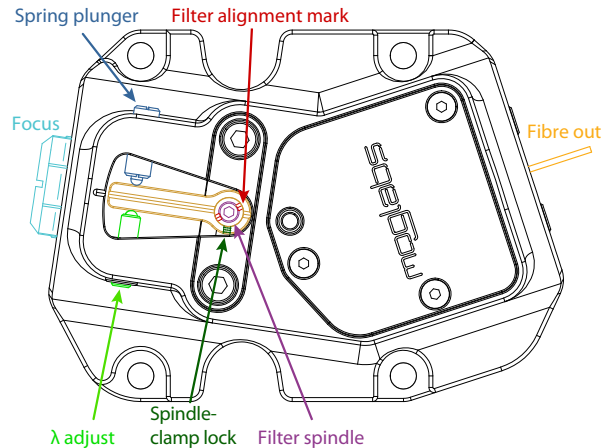

Figure 3.1: CES key components for wavelength and focus adjustment. Filter angle adjustment, showing the primary (fine) wavelength adjustment screw and counter-acting spring plunger; filter alignment mark and spindle-clamp locking screw for coarse wavelength adjustment; rear cateye focus adjustment for current threshold optimisation; fibre output.

After the target wavelength has been achieved, SPAN can be adjusted to increase the width of the piezo scan. Adjustments of the SPAN knob should be gradual, and careful adjustments of the diode current and piezo may be required in order to maintain single-mode operation. Confirm that your laser is capable of reaching the mode-hop free scan range (MHFR) specified in the laser test report. If the MHFR is less than specified, proceed to sections 3.3 and 4.1.

3.3 Mode-hops

Mode-hops are a frequent occurrence with external cavity diode lasers. A mode-hop is a discontinuity when tuning or scanning the laser wavelength. As the laser wavelength is varied, usually by changing the cavity length with a piezo, competition between the wavelength determined by the different wavelength-dependent cavity elements can lead to a *mode hop*: a jump in laser wavelength to a different external cavity mode. Wavelength-

dependent elements include the external cavity, the laser diode internal cavity between the rear and front facets of the diode, the filter, and the gain bandwidth of the laser diode.

The different wavelength-dependent characteristics are shown schematically in figure 3.2. The net gain is the product of semiconductor gain, filter response, and internal and external cavity interference. The net gain can be very similar at adjacent external cavity modes. A small change in the laser cavity optical path length, the diode internal cavity mode frequency, or the filter angle, can lead to the overall gain being greater at a mode adjacent to the mode in which the laser is oscillating, and the laser then hops to that higher-gain mode. See Ref. [6] for a detailed discussion.

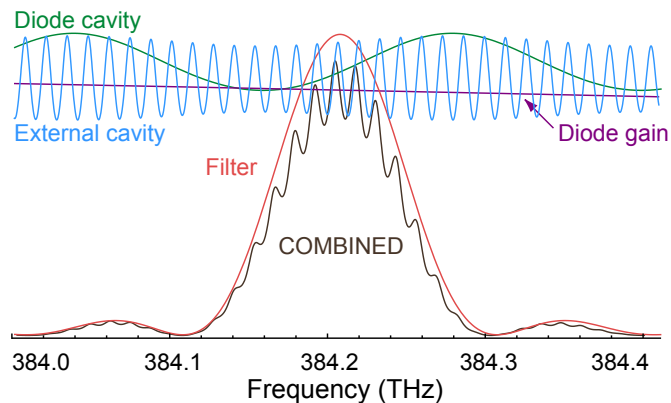

Figure 3.2: Schematic representation for the various frequency-dependent factors of an ECDL, adapted from Ref. [6], for wavelength $\lambda = 780$ nm and external cavity length $L_{\text{ext}} = 15$ mm.

3.4 Scanning

The external cavity length is controlled by a piezo actuator moving the external cavity mirror. The cavity length changes with piezo voltage, and for a large change, the laser will usually hop to a neighbouring cavity mode. Figure 3.3 is a schematic of the net gain variation with laser frequency, showing two adjacent modes of very similar gain. Figure 3.4 is

a measurement of the frequency of a laser scanning properly, and with a mode-hop at one edge of the scan.

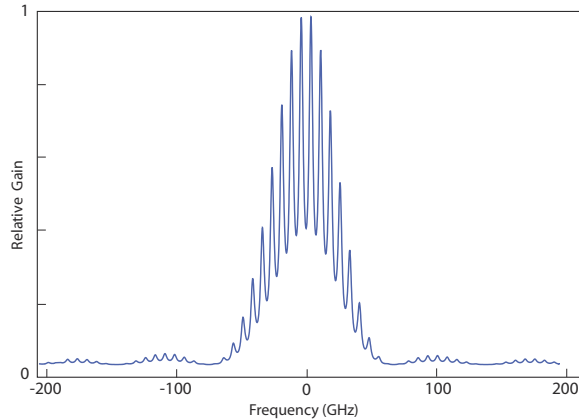

Figure 3.3: Combined gain for an external cavity diode laser, including the internal and external modes, the diode laser gain, and the filter response. The broad feature is the frequency selectivity of the filter, and the smaller peaks are the external cavity modes (see figure 3.2). The laser will easily hop between the two highest external modes with similar net gain.

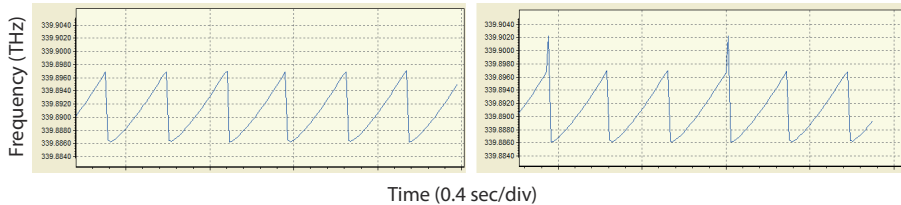

Figure 3.4: Laser frequency vs. time for a laser with a 4Hz piezo ramp rate, giving about 10 GHz of cavity frequency change when scanning mode-hop-free properly (left) and with a mode-hop at one edge (right).

The mode-hop-free range (MHFR) can be optimised by careful adjustment of the injection current, which affects the optical path length of the diode and hence the frequency of the cavity mode.

4. Troubleshooting

4.1 Scanning adjustment

Achieving a wide continuous mode-hop free wavelength scan requires careful optimisation of the control parameters, including laser diode current, focus, and feed-forward current bias. The laser has been carefully tuned to the wavelength and scan range specified in the laser test report. The instructions below describe how to achieve the maximum mode-hop free range (MHFR).

The first step is to confirm that the laser is indeed scanning, for example with a wavemeter such as the MOGLabs Fizeau wavemeter (FZW), MOGLabs economical wavemeter (MWM), or a Fabry-Perot cavity.

1. Slowly increase SPAN while monitoring the frequency change with a wavemeter.
2. If there is no change in scan range, then disable feed-forward current bias using DIP switch 4 in the DLC. If there is no evidence that the laser is scanning with bias disabled, then the piezo has failed; please contact MOGLabs for assistance.
3. If the laser scans with bias disabled, adjustment of CURRENT and BIAS (once DIP switch 4 is enabled again) can be used to increase the scan range. Slowly increase SPAN, and use small adjustments of CURRENT and piezo offset FREQUENCY to suppress mode-hops.
4. Increase SPAN to the maximum before mode-hops are evident.
5. Observe the CHAN B Current output to measure the BIAS; that is, the change in diode current over the scan range. If the peak-to-peak voltage of CHAN B Current is significantly less than that specified in the laser test report, BIAS adjustment is required. For a CES laser, the BIAS is typically set to maximum negative value (fully anti-clockwise).

4.1.1 BIAS optimisation

Ideally the frequencies of the external cavity mode and the intrinsic laser diode mode are identical (see figure 3.2). The external mode frequency is controlled by the piezo. The intrinsic diode mode frequency can be controlled by adjusting the laser diode current.

The diode injection current can be “automatically” adjusted as the laser frequency is changed, using a “feed-forward” or current bias which changes as the piezo voltage is changed. Feed-forward current bias adjustment is a feature of MOGLabs DLC controllers. Each laser requires a different change in diode current for a given change in piezo, and the ratio can be adjusted with the BIAS trimpot on the DLC controller.

Optimisation is straightforward. With the laser frequency scanning, the BIAS control is adjusted until the maximum mode-hop-free scan range is observed. Small changes to the injection current optimise the scan range near the nominal centre frequency. A fast Fizeau wavemeter, an atomic absorption spectroscopy signal, or a Fabry-Perot cavity can be used to monitor the laser frequency while varying the different control parameters.

1. Ensure that BIAS is enabled (DIP switch 4).
2. Referring to the laser test report CH A FREQ in the *Tuning tests (final tuned wavelength)* section, adjust SPAN while monitoring CHAN A Freq and CHAN B Current on a dual-channel oscilloscope. Confirm that the peak-to-peak voltages on the two sawtooth outputs match the values specified in the laser test report by first matching CHAN A Freq using SPAN only. Now adjust BIAS until the peak-to-peak voltage for CHAN B Current agrees with the CH B CURRENT in the laser test report, noting also the sign/gradients should agree with the laser test report.
3. Reduce SPAN to zero. Adjust the laser diode CURRENT to find the required laser wavelength and approximate output power.
4. If the wavelength is close but not quite correct, small adjustments of either CURRENT or FREQUENCY may be required to find a better

lasing mode. If more significant wavelength adjustment is required, mechanically rotate the filter (see section 4.2).

5. If the wavelength is within a few picometres (GHz) of the target, increase SPAN while observing the wavelength scan as shown in figure 3.4.
6. Increase SPAN until a mode-hop is evident. If using absorption spectroscopy to monitor the laser wavelength, it can be helpful to observe the derivative, for example the demodulated error signal (CHAN B Error on a MOGLabs DLC).

The mode hop should be at one edge of the scan; if so, adjust FREQUENCY so that the scan no longer 'clips' this mode hop (i.e. the scan is free of mode hops), and continue adjusting in the same direction until a mode hop is observed on the other edge of the scan.

7. Adjust FREQUENCY to the mid-point between the two extremes.
8. Increase SPAN and adjust FREQUENCY until mode hops are evident at both edges of the scan.
9. Adjust diode CURRENT by small amounts to suppress the mode hops. Increase SPAN and adjust CURRENT and FREQUENCY until the mode hops cannot be suppressed.
10. Adjust the BIAS trimpot to suppress the mode hops. Typically for a CES laser the BIAS trimpot should be fully anti-clockwise. Repeat the steps above: increase SPAN, adjust CURRENT, FREQUENCY and BIAS, and repeat until no further improvements can be made.
11. If the MHFR is substantially less than expected (refer to the factory test report), it may be helpful to optimise the focus; see section 4.3.
12. If the MHFR is still less than expected, it may be helpful to change to a different intrinsic diode mode by increasing or decreasing CURRENT. Alternately rotate the filter slightly to alter the net gain so that one cavity mode has higher gain than those adjacent.

4.2 Filter adjustment

The primary control of wavelength is the filter rotation angle, which can be adjusted while the laser is operational. A MOGLabs Fizeau wavemeter or high-resolution spectrometer is almost essential, though with patience it is possible to find an atomic resonance by carefully adjusting the filter angle while scanning the laser.

Note that the cateye lens focus is wavelength dependent, so whenever the laser wavelength is changed substantially (more than say 5–10 nm), we recommend also optimising the current threshold (see sec. 4.3).

To change the wavelength:

1. Set the laser current so that the output power is sufficient, taking care to ensure that the internal cavity power is below the maximum rated for the bare diode i.e. without feedback, if applicable (see figure 2.1).

For adjustments of greater than 1nm:

2. Unlock the filter so that it can rotate, by turning the spindle-clamp lock screw anti-clockwise, for example one full turn.
3. Rotate the filter assembly spindle using an allen key or hex ball driver in the hex socket in the centre of the shaft, making sure that the notch does not align at 0° to the laser body.
4. Re-lock the spindle-clamp.
5. Optimise the cateye focus (refer sec. 4.3).

For adjustments of less than 1nm:

6. Check that the spring-plunger is engaged but not locked against the brass arm of the spindle clamp. That is, the pin should be visibly protruding from the spring-plunger screw, and touching the brass arm.
7. Adjust the filter angle using the fine thread λ adjust screw, acting against the spring-loaded plunger opposite to the λ adjust screw.

8. The laser will hop between external cavity modes as the wavelength is adjusted, through cycles of dim and bright output.
9. It may be necessary to adjust the spring plunger, so that pressure is maintained on the brass arm of the spindle clamp, without locking completely.
10. Once the laser is operating near the desired wavelength, adjust the diode current and the piezo voltage to achieve the exact wavelength required. If the CURRENT adjustment has shifted the wavelength to a mode further away from the desired wavelength, use the fine screw adjustment method to correct the wavelength.

The filter transmission wavelength shifts with rotation according to

$$\lambda(\theta) = \lambda_0 \sqrt{1 - \left(\frac{\sin(\theta)}{n_{\text{eff}}} \right)^2} \quad (4.2.1)$$

where θ is the angle of incidence, λ_0 is the filter wavelength at normal incidence and $n_{\text{eff}} \approx 1.7$ is an effective refractive index. The sensitivity to rotation of the fine tangential wavelength adjustment screw is about 0.5 nm to 1 nm per turn.

4.3 Threshold optimisation

The lasing threshold, at which the overall gain exceeds losses, should be as low as possible to maximise the output power and also the scan range and frequency stability. The lowest threshold is achieved by optimising the focus of the cateye lens (see figure 3.1). The cateye lens focus is wavelength dependent, so whenever the laser wavelength is changed substantially, we recommend also optimising the threshold. Note also that the gain curve of the SAF laser diode has a current-dependent wavelength shift; optimising the cateye lens focus at low currents does not necessitate optimised feedback at higher/operating currents.

If the CES output wavelength is near a diode gain edge, the current threshold can be much higher than expected and hence difficult to optimise. For this reason, a general approach to threshold optimisation is:

1. Increase the laser diode current to the maximum safe current specified in the laser test report.
2. Optimise the CES output power by adjusting the cateye lens focus. The cateye lens focus is adjusted by rotating the threaded lens holder (see figure 3.1), using the tool provided with the laser, a wrench or a flat-blade screwdriver.

If it is not possible to obtain the output power expected, first ensure the filter angle is not set to a wavelength at or beyond an edge of the diode gain curve by using e.g. a MOGLabs FZW Fizeau wavemeter (refer to the laser diode manufacturer datasheet for the gain curve). If the output wavelength is well within the gain curve, a more involved procedure to optimise the cateye lens focus is described below:

1. Ensure the DLC is off or on standby.
2. Take note of the filter angle by marking on the laser barrel the alignment of the filter assembly notch (the mark on the aluminium spindle, not the mark on the brass clamp) relative to the laser barrel notch. Take a photo from above, so that you can restore the original filter angle if needed.
3. Loosen the spindle-clamp lock screw and rotate the filter spindle such that the filter alignment mark (the mark on the aluminium spindle, not the mark on the brass clamp) is aligned with the laser barrel notch. Tighten the spindle-clamp lock screw back onto the spindle.
4. Unscrew and remove the two socket head cap screws either side of the filter spindle.
5. Undo the spring plunger and wavelength adjust screws until they are well clear and no longer touching the brass filter adjust clamp.
6. Gently prise the filter assembly from the laser barrel (see figure 4.1). If necessary, use pliers to gently grip the brass adjuster, or flat blade tweezers to lever the brass adjuster, or turn the laser upside down

so the assembly drops out (be very careful not to stress the fibre output). Excessive force should not be required. If the filter seems stuck, it's because the filter angle isn't quite aligned.



Figure 4.1: Removing the intracavity filter assembly.

7. Connect a fibre-coupled power sensor and power meter to monitor the laser output power. An integrating sphere type sensor is much preferred due to the tendency for small spots size to saturate photodiode based sensors.
8. Turn the DLC on and adjust CURRENT to 5-10 mA above the threshold specified in the laser test report. You should have at least 1 mW of output power, otherwise increase the current further, but do not exceed the maximum safe current specified in the laser test report.
9. Adjust the cateye lens focus to optimise the output power by rotating the focus knob using the tool provided with the laser, a wrench or a flat-blade screwdriver.
10. Iterate reducing the injection current to obtain 1 mW, followed by focus adjustment of the cateye to optimise power, until the minimum current threshold is achieved.
11. Turn off the current, reassemble the laser and adjust the filter angle to approximately the angle you require for your desired wavelength, as noted at the start of this enumerated sequence with a photo or mark on the laser barrel.

12. Turn on the current to the maximum safe current specified in the laser test report and fine-adjust the filter angle to achieve the desired wavelength by monitoring on e.g. a MOGLabs FZW Fizeau wavemeter.
13. Increase the laser diode current to the operating current if not already exceeded, then do a final optimisation of the CES output power at this wavelength by adjusting the cateye lens focus.

A. Specifications

Parameter	Specification
-----------	---------------

Wavelength and peak power	
960 – 1080 nm	200 mW, no isolator
1080 – 1200 nm	100 mW, no isolator
1170 – 1270 nm	10 mW, with isolator
1250 – 1390 nm	70 mW, with isolator
1420 – 1520 nm	40 mW, with isolator
1510 – 1610 nm	40 mW, with isolator
1860 – 1970 nm	7 mW, no isolator
Linewidth	Typically < 25 kHz
Filter	0.2 to 0.4 nm bandpass
Tuning range	Diode dependent, up to 100 nm Full range may require multiple filters

Sweep/scan	
Scan range	> 20 GHz
Mode-hop free	> 10 GHz; typically 20 GHz
Piezo	3 μm @ 150 V, 100 nF (typical)

Fibre	
Polarisation	Polarisation maintaining > 20 dB (100:1)
Connector	FC/APC

Parameter	Specification
-----------	---------------

Thermal	
TEC	$\pm 14.5\text{ V}$ 3.3 A $Q = 23\text{ W}$ standard
Sensor	NTC 10 k Ω standard; AD590, 592 optional
Stability at base	$\pm 1\text{ mK}$ (controller dependent)
Cooling	Optional: 4 mm diam quick-fit connections

Electronics	
Protection	Diode short-circuit relay; cover interlock connection; reverse diode
Indicator	Laser ON/OFF (LED)
Connector	MOGLabs Diode Laser Controller single cable connect
Modulation input	Active (AC and DC coupled)

Mechanical & power	
Dimensions	108 \times 70 \times 83 mm (L \times W \times H), 1 kg
Beam height	58 mm
Shipping	420 \times 360 \times 260 mm (L \times W \times H), 3.1 kg

A.1 CES mechanical

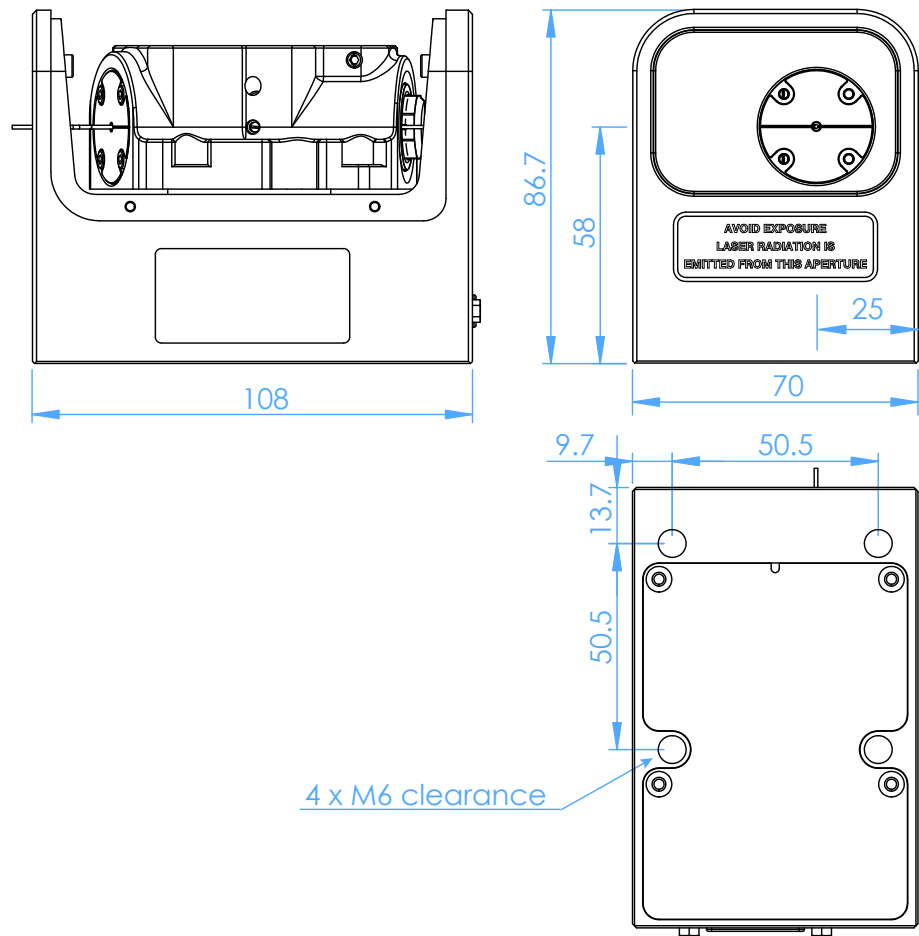

Figure A.1: Dimensions of CES laser head.

B. Laser head electronics

Within the laser head there are two electronic circuit boards, the B1080 and B1085/B1086. B1085/B1086 is a flexible circuit board that connects directly to the B1080 laser headboard. B1085/B1086 acts as mount for the SAF butterfly laser diode and has connection for a thermistor. B1080 has a DVI-D DL socket for connection to the MOGLabs DLC laser controller and a connector for the B1085/B1086 flexible circuit board. It also includes passive protection filters, a laser-on LED indicator, and an SMA connection for direct diode current modulation.

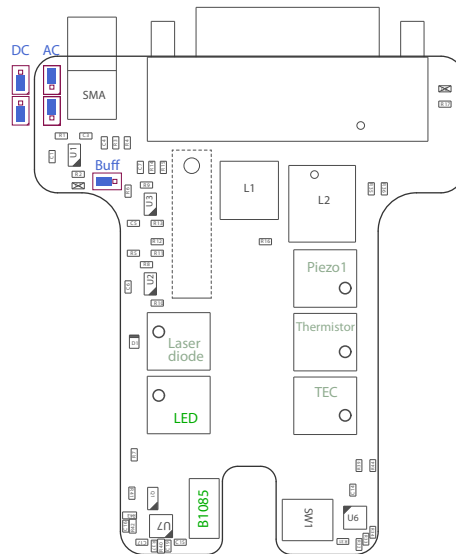

Figure B.1: B1080 laser headboard. Jumpers at top left can be configured for AC or DC coupling, and “Buf” for buffered or direct input coupling. Buf is shown connected for buffered input; change to pins 1 and 2 for direct. Modulation input via SMA connector, sensitivity 2.5 mA/V. Connectors are JST S2B-EH.

B.1 SMA input

The SMA input provides AC or DC coupling high bandwidth active current modulation for wide bandwidth frequency stabilisation and linewidth narrowing, for example using a high finesse optical cavity or polarisation spectroscopy. Note that connection to the SMA input will reduce the diode current by about 2.5 mA with zero input voltage. Ground connection is direct or buffered; the latter is about 10% slower but reduces problems with ground-loop noise.

	B1080
Input range	$\pm 2.0\text{ V max}$
Input coupling	DC (direct) AC/DC (buffered)
AC time constant	$15\ \mu\text{s}$ (10 kHz)
Phase delay	$< 20\ \text{ns}$ (direct) $< 30\ \text{ns}$ (buffered)
Gain bandwidth ($-3\ \text{dB}$)	20 MHz
Input impedance	AC buffered: $1\ \text{k}\Omega$ at 10 kHz DC buffered: $1\ \text{k}\Omega$ Direct: $1\ \text{k}\Omega$
Current gain	$1\ \text{mA/V}$
Laser diode voltage	$2.5\ \text{V max}$

B.2 Headboard connection to controller

Note The MOGLabs laser cable is a digital DVI-D DL (*dual link*) cable. There is a bewildering assortment of apparently similar cables available. Most *computer display* DVI cables will *not* work because they are missing important pins; see diagram below. Only high quality digital *dual-link* DVI-D DL cables should be used.

Pin	Signal	Pin	Signal	Pin	Signal
1	TEC -	9	DIODE -	17	DISC +
2	TEC +	10	DIODE +	18	DISC -
3	Shield	11	Shield	19	Shield
4	TEC -	12	DIODE -	20	STACK +
5	TEC +	13	DIODE +	21	STACK -
6	$T_{\text{sense}} -$	14	Relay GND	22	
7	$T_{\text{sense}} +$	15	+5V in	23	NTC -
8		16	Interlock out	24	NTC +

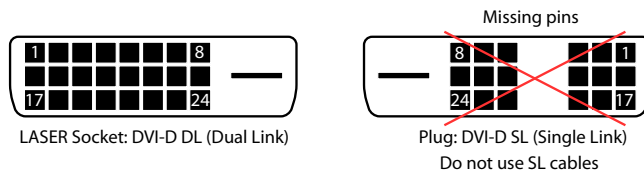

Figure B.2: Headboard connector. Note that the pinout is different to that of the matching connector on the rear of the DLC controller.

A 10 k thermistor should be connected to NTC+ and NTC-, but an AD590 or AD592 temperature sensor can be instead be connected to T_{sense} . Pin 15 should be connected to a +5V supply. To activate the laser diode, relay GND (pin 14) should be grounded to open the relay that otherwise short-circuits the diode current. +5V (pin 15) is internally connected to pin 16 (Interlock), normally with a permanent connection but on some headboards (see above), a connector is provided to allow connection to a cover-activated microswitch to disable the laser when the cover is removed.

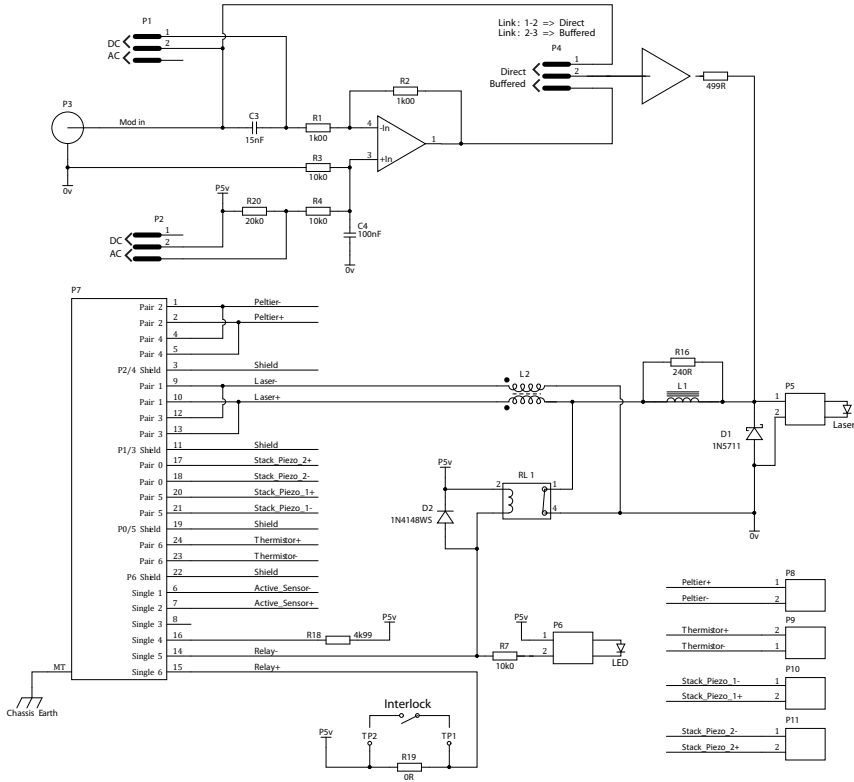

Figure B.3: MOGLabs laser headboard schematic (B1080).

Bibliography

- [1] Daniel J. Thompson and Robert E. Scholten. Narrow linewidth tunable external cavity diode laser using wide bandwidth filter. *Review of Scientific Instruments*, 83(2):–, 2012. 1, 2
- [2] X. Baillard, A. Gauguet, S. Bize, P. Lemonde, Ph. Laurent, A. Clairon, and P. Rosenbusch. Interference-filter-stabilized external-cavity diode lasers. *Opt. Communic.*, 266:609, 2006. 1, 2
- [3] M. Gilowski, Ch. Schubert, M. Zaiser, W. Herr, T. Wübbena, T. Wendrich, T. Müller, E.M. Rasel, and W. Ertmer. Narrow bandwidth interference filter-stabilized diode laser systems for the manipulation of neutral atoms. *Optics Communications*, 280(2):443 – 447, 2007. 1, 2
- [4] H. Talvitie, A. Pietiläinen, H. Ludvigsen, and E. Ikonen. Passive frequency and intensity stabilization of extended-cavity diode lasers. *Rev. Sci. Inst.*, 68(1):1, 1997. 3
- [5] S. D. Saliba and R. E. Scholten. Linewidths below 100 khz with external cavity diode lasers. *Appl. Opt.*, 48(36):6961, 2009. 3
- [6] S. D. Saliba, M. Junker, L. D. Turner, and R. E. Scholten. Mode stability of external cavity diode lasers. *Appl. Opt.*, 48(35):6692, 2009. 3, 11

